



LISTING INFORMATION OF
EFS Engineering Insulation
SPEC ID: 46247

EFS Engineering LTD
393 Harishonim St.
PO Box 393
Ein Vered, X 40696
Israel

This report is for the exclusive use of Intertek's Client and is provided pursuant to the agreement between Intertek and its Client. Intertek's responsibility and liability are limited to the terms and conditions of the agreement. Intertek assumes no liability to any party, other than to the Client in accordance with the agreement, for any loss, expense or damage occasioned by the use of this report. Only the Client is authorized to permit copying or distribution of this report and then only in its entirety. Any use of the Intertek name or one of its marks for the sale or advertisement of the tested material, product or service must first be approved in writing by Intertek. The observations and test results in this report are relevant only to the sample tested. This report by itself does not imply that the material, product, or service is or has ever been under an Intertek certification program.

LISTING INFORMATION

PRODUCT DESCRIPTION

Ductz+, EFS Wrap, FlameWrap Ductz 120 Model 1.1 and Model 2.1 and Ductz+, EFS Wrap, and FlameWrap Model 1.2 and 2.2 are encapsulated insulation blankets having a nominal thickness of 1-1/2 inches and a nominal density of 6 pcf. The core material is a high temperature fiber. The core insulation blanket is completely encapsulated in an aluminum foil fiberglass reinforced scrim covering.

MATERIAL RATINGS FOR DUCTZ+, EFS WRAP, FLAMEWRAP DUCTZ120 MODEL 1.1 AND MODEL 1.2

Test Standard	Test Type	Rating
ASTM C518	Thermal Conductivity; Durability (per ASTM E2336); Serviceability-Thermal Transmission Properties (per UL 2221)	Control Specimens: Average 4.29 h-ft ² ·°F/Btu/in. Thermally Cycled Specimens: Average 4.37 h-ft ² ·°F/Btu/in. Meets related requirements of ASTM E2336 and UL 2221
ASTM E136	Combustibility	Meets requirements for Noncombustibility
ASTM C411	Serviceability - Hot Surface Performance (per UL 2221) @ 479 +/- 23.9 °F	Meets related requirements of UL 2221

FLAME SPREAD RATINGS FOR DUCTZ+, EFS WRAP, FLAMEWRAP DUCTZ120 MODEL 1.1 AND MODEL 1.2

Test Standard	Flame Spread	Smoke Development
ASTM E84	does not exceed 25	does not exceed 50

FIRE RESISTANCE RATINGS (REFERENCE PRODUCTS IN RESPECTIVE DESIGN LISTING)

Test Standard	Rating	Design No.
ASTM E2336	2 Hr	EFS/BI 120-01 EFS/BI 120-02
ASTM E119	2 Hr	EFS/BI 120-01 EFS/BI 120-02
CAN/ULC-S144	2 Hr	EFS/BI 120-01 EFS/BI 120-02
UL 2221	2 Hr (Condition A)	EFS/BI 120-02
ASTM E814 and UL 1479	T-Rating: 2 Hr F-Rating: 2 Hr	EFS/BI 120-01 EFS/BI 120-02

CAN/ULC-S115	F-Rating: 2 Hr FT-Rating: 2 Hr FH-Rating: 2 Hr FTH- Rating: 2 Hr	EFS/BI 120-01 EFS/BI 120-02
ISO 6944-1985	Horizontal Condition A Stability: 2 Hr Insulation: 1.5 Hr Integrity: 2 Hr	EFS/BI 90-01
ISO 6944-1985	Vertical Condition A Stability: 2 Hr Insulation: 2 Hr Integrity: 2 Hr	EFS/BI 120-03

Attribute	Value
Certificate Date of Expiry	December 31, 2022
Certificate Date of Initial Registration	October 5, 2020
Certificate Number	WHI20 - 30351901
Criteria	ISO 6944 (1985)
Criteria	ASTM C411 (2005)
Criteria	UL 2221 (2010)
Criteria	ASTM C518 (2010)
Criteria	CAN / ULC S115 (2011)
Criteria	CAN / ULC S144 (2012)
Criteria	ASTM E84-18a
Criteria	ASTM C411 (2017)
Criteria	ASTM C518 (2017)
Criteria	UL 1479 (2015) Ed.4
Criteria	UL 1479 (2012)
Criteria	ASTM E2336 (2016)
Criteria	ASTM E814-13a (R2017)
Criteria	ASTM E136 (2016) Ed.16a
Criteria	ASTM E119 (2018a)
Criteria	ASTM E84-18
CSI Code	07 21 00 Thermal Insulation
CSI Code	07 21 16 Blanket Insulation
Intertek Services	Certification
Listed or Inspected	LISTED
Listing Section	BUILDING MATERIALS WITH SURFACE BURNING CHARACTERISTICS
Listing Section	FIRE RESISTANT DUCT
Listing Section	NON-COMBUSTIBLE MATERIALS

Listing Section
Spec ID

THERMAL INSULATION
46247

DRAWING INDEX

EFS/BI 120-01

EFS/BI 120-02

EFS/BI 120-03

EFS/BI 90-01

EFS/BI 120-01



Division 07 – Thermal and Moisture Protection
 07 21 00 Thermal Protection
 07 21 16 Blanket Insulation

EFS Engineering Ltd.
Design No. EFS/BI 120-01
FIRE RESISTANT GREASE DUCT
Ductz+, EFS Wrap, FlameWrap, and Ductz120 Model 1.1

ASTM E2336
 Non-combustibility Test (ASTM E136): Pass
 Fire Resistance Test (ASTM E119): 2 Hour
 Durability Test (ASTM C518 modified): Pass
 Internal Fire Test – 4 Hour @ 500°F and 30 Minutes @ 2000°F: Pass
 Fire-Engulfment Test (ASTM E119 Exposure): 2 Hour
CAN/ULC-S144
 Rating: 2 Hour
ASTM E814 and UL 1479
 F-, T-Rating: 2 Hour
CAN/ULC-S115
 F-, FT-, FH-, FTH-Rating: 2 Hour

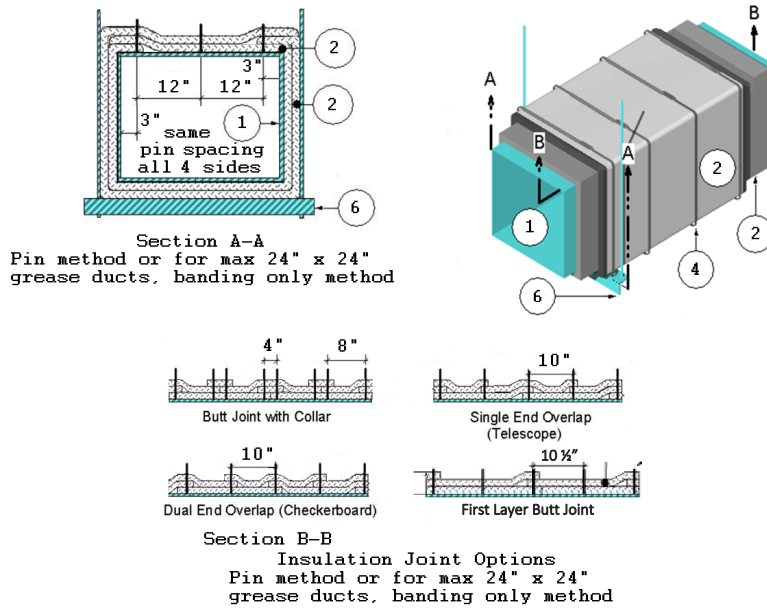

Figure 1. EFS Ductz+ Grease Duct Insulation System

EFS/BI 120-01 (2 OF 13)



Division 07 – Thermal and Moisture Protection
 07 21 00 Thermal Protection
 07 21 16 Blanket Insulation

1. GREASE DUCT: Use a continuously welded, liquid-tight, rectangular or round duct system with horizontal and vertical shafts constructed to the following min. requirements:

- A. STEEL – Min. 16 GA carbon steel
- B. JOINTS – Continuously welded, liquid-tight construction
- C. CROSS-SECTIONAL SHAPE – Rectangular or Round
- D. CROSS-SECTIONAL DIMENSIONS –
 - i. Rectangular: Max. 54 in. x 54. in.
 - ii. Round: Max. 54 in. diameter
- E. When required, equip the duct with an access door (Item 5)
- F. Reinforce the grease duct to NFPA 96 requirements designed to carry the weight of the grease duct assembly covered with two layers of duct insulation (Item 2) under a fire load equivalent to that of the ASTM E119 time-temperature curve for the rated period.
- G. Rigidly support the grease duct as specified in Item 6 or in accordance with International Mechanical Code (IMC), NFPA 96, or other applicable requirements, when not specified herein or when those requirements are greater.

2. CERTIFIED MANUFACTURER: EFS Engineering Ltd.

CERTIFIED PRODUCT: Duct Insulation

CERTIFIED MODELS: Ductz+, EFS Wrap, FlameWrap, and Ductz120 Model 1.1 (Ductz+ used as example in design listing)

Apply two layers of the nominal 1-1/2 in. thick, nominal 6 pcf density duct insulation over the entire surface of the grease duct (Item 1).

- A. STANDARD INSTALLATION – Apply both layers of duct insulation with transverse and longitudinal joints as shown in Figure 1. For rectangular grease ducts (Item 1), locate inner layer longitudinal joints (Figure 1) at a corner of the grease duct (Item 1), and offset the outer layer joint (Figure 1) to a different corner. For horizontal sections, ensure the longitudinal joints are placed at the top corners. For round grease ducts (Item 1), locate inner layer longitudinal joints and outer layer longitudinal joints 90° apart; for horizontal sections, center the joints on the top of the grease duct (Item 1). Use a min. 4 in. overlap at all insulation joints. Optional: for rectangular ducts only, compressed butt joints may be used on the first layer and horizontal sections only. Transverse butt joints with collar shall use a min. 8 in. wide collar with min. 4 in. overlap on each side of the butt joint. Use blanket, available in various widths, fully encapsulated with a polypropylene foil scrim. Cover all visually exposed ends and edges of duct insulation with nominal 3 in. wide aluminum foil tape. Tape all joints (inner and outer layers; longitudinal and transverse) with nominal 3 in. wide aluminum foil tape (reference Figure 2).



Figure 2: Aluminum Tape Installation Detail at Inner and Outer Layer Insulation Joints (tape shown in blue)

- B. THREE-SIDED INSTALLATION – Refer to Figures 3 and 4.

EFS/BI 120-01 (3 OF 13)



Division 07 – Thermal and Moisture Protection
07 21 00 Thermal Protection
07 21 16 Blanket Insulation

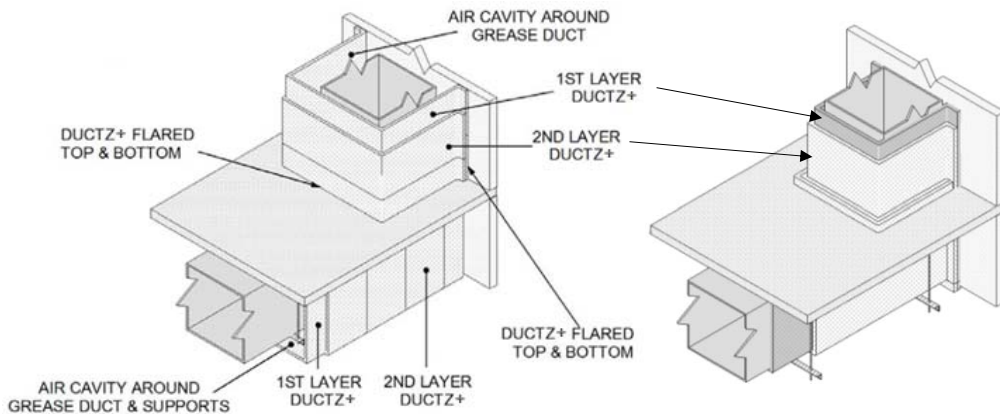

Figure 3. Three-Side Installation Top Isometric (Shown with and without Optional Air Cavity)

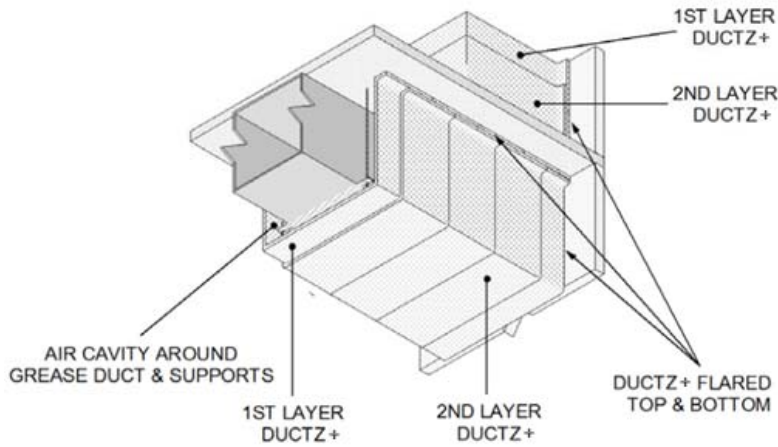

Figure 4. Three-Side Installation Bottom Isometric (Shown with Optional Air Cavity)

EFS/BI 120-01 (4 OF 13)



Division 07 – Thermal and Moisture Protection
 07 21 00 Thermal Protection
 07 21 16 Blanket Insulation

When the grease duct (Item 1) is positioned within 12 in. of a 2 hr fire-rated wall or ceiling, use a three-sided installation method. Apply both layers of duct insulation in general accordance with conditions specified in Item 2A with the following additional conditions and modifications:

- i. Floor/Ceiling Assembly: Min. 2 hr fire-rated, reinforced concrete.
- ii. Wall Assembly: Min. 2 hr fire-rated, reinforced concrete; min. 2 hr fire-rated concrete masonry unit (CMU); min. 2 hr fire-rated, steel stud framing with min. two layers of 5/8 in., Type X gypsum board on each side.
- iii. Supports: Position horizontal supports (Item 6) inside of the duct insulation (Item 2), or on the outside of the duct insulation (Item 2). For installation of supports inside the insulated space, apply a min. 6 in. wide strip of un-encapsulated duct insulation (Item 2) between the grease duct (Item 1) and the horizontal supports (Item 6); and space the supporting threaded steel rods 1-1/2 in. ± 1/2 in. from the surface of the uninsulated grease duct.
- iv. Insulation Anchors: Floor/Ceiling Application – Use min. 16 GA, min. 1-1/2 in. wide steel sheet strips, and min. 1/4 in. diameter hex-head concrete anchors, spaced to match the longitudinal pin spacing shown in Figure 1. Position the floor/ceiling anchors over a min. 6 in. wide horizontal flange of the flared duct insulation (Item 2) which is in contact with the floor/ceiling assembly. Position the anchors such that the duct insulation extends a min. 1-1/2 in. beyond the anchors. Refer to Figure 6.
- v. Insulation Anchors: Wall Application – Use min. 16 GA, min. 1-1/2 in. wide steel sheet strips. For concrete or masonry wall, fasten the duct insulation (Item 2) to the wall using min. 1/4 in. diameter hex-head concrete or masonry anchors as applicable, and spaced to match the longitudinal pin spacing shown in Figure 1. For gypsum wall, use min. 1/4 in. diameter hex-head self-drilling screws spaced to match the longitudinal pin spacing shown in Figure 1. Position the wall anchors over a min. 6 in. wide flange of the flared duct insulation (Item 2) which is in contact with the wall assembly. Position the anchors such that the duct insulation extends a min. 1-1/2 in. beyond the anchors. Refer to Figure 6. For steel stud and gypsum wall attachment, ensure that studs are positioned in line with the wall anchors.
- vi. Gypsum Anchor Protection Boards: For installation onto steel stud and gypsum wall, use three layers of 6 in. wide, 5/8 in. Type X gypsum board strips, mounted vertically onto the gypsum wall under the duct insulation (Item 2) and adjacent to the wall anchors (Item 2Bvi) as shown in Figure 6. Attach the gypsum wall anchor boards with #10 drywall Type G laminating screws spaced 24 in. on center (oc). Secure the insulation blanket (Item 2) to the gypsum wall anchor board using wall anchors (Item 2Bvi) consisting of min. 16 GA, min. 1-1/2 in. wide steel sheet strips and #10 drywall Type G laminating screws spaced to match the longitudinal pin spacing shown in Figure 1.

Date Revised: June 21, 2022

Page 4 of 13

Project No. G103127034

Version: 02 August 2017

SFT-BC-OP-19I

EFS/BI 120-01 (5 OF 13)



Division 07 – Thermal and Moisture Protection
07 21 00 Thermal Protection
07 21 16 Blanket Insulation

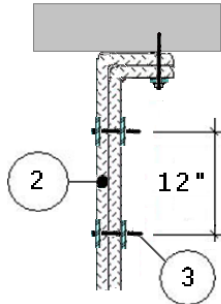

Figure 5. Pin Method for Duct Insulation to Floor/Ceiling or Wall for Three-Sided and Two-Sided Installation for Round Ducts

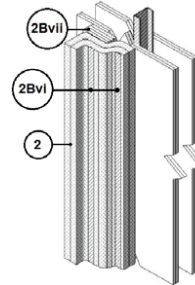

Figure 6. Wall Anchoring

C. TWO-SIDED INSTALLATION – Refer to Figures 7 and 8.

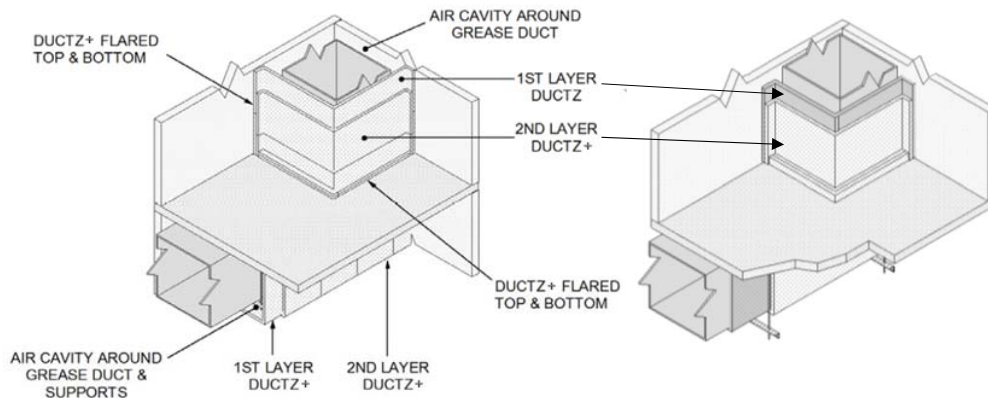

Figure 7. Two-Side Installation Top Isometric (Shown with and without Optional Air Cavity)

EFS/BI 120-01 (6 OF 13)



Division 07 – Thermal and Moisture Protection
07 21 00 Thermal Protection
07 21 16 Blanket Insulation

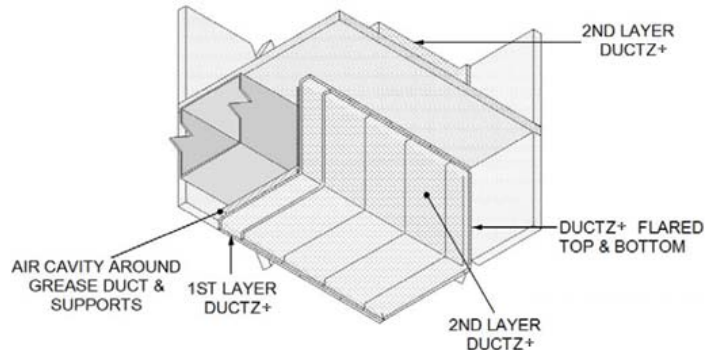

Figure 8. Two-Side Installation Bottom Isometric (Shown with Optional Air Cavity)

When the grease duct (Item 1) is positioned within 12 in. of a 2 hr fire-rated wall and ceiling, or within 12 in. of two adjacent 2 hr fire-rated walls, use a two-sided installation method. Apply both layers of duct insulation in general accordance with conditions specified in Item 2A with the following additional conditions and modifications:

- i. Floor/Ceiling Assembly: Min. 2 hr fire-rated, reinforced concrete.
- ii. Wall Assembly: Min. 2 hr fire-rated, reinforced concrete; min. 2 hr fire-rated concrete masonry unit (CMU); min. 2 hr fire-rated steel stud framing, and min. two layers of 5/8 in. Type X gypsum board on each side.
- iii. Supports: Position horizontal supports (Item 6) inside of the duct insulation (Item 2) or on the outside of the duct insulation (Item 2). For installation of supports inside the insulated space, apply a min. 6 in. wide strip of unencapsulated duct insulation (Item 2) between the grease duct (Item 1) and the horizontal supports (Item 6); and space the supporting threaded steel rods 1-1/2 in. \pm 1/2 in. from the surface of the uninsulated grease duct. For installation on the outside of the duct insulation (Item 2), anchor the wall-facing side of the supports (Item 6) to the wall using min. 3 in. wide L-shaped brackets made from min. 3 in. \times 3 in. \times 1/4 in. steel angle. Fasten the brackets to the wall with a min. of two 1/4 in. diameter steel fasteners of the appropriate type for the wall construction. In the case of steel stud wall construction, fasten the brackets into steel studs. When the supports (Item 6) are located outside of the duct insulation (Item 2), install the brackets over the flared duct insulation (Item 2). Fasten the support (Item 6) to the bracket using a 1/2 in. steel bolt, nut and washer.
- iv. Insulation Anchors: Floor/Ceiling Application – Use min. 16 GA, min. 1-1/2 in. wide steel sheet strips, and min. 1/4 in. diameter hex-head concrete anchors, spaced to match the longitudinal pin spacing shown in Figure 1. Position the floor/ceiling anchors nominal 4 in. from the outer surface of the duct insulation (Item 2). Extend the duct insulation min. 1-1/2 in. beyond the anchors. Reference Figure 9.
- v. Insulation Anchors: Wall Application – Use min. 16 GA, min. 1-1/2 in. wide steel sheet strips. For concrete or masonry wall, fasten the duct insulation (Item 2) to the wall using min. 1/4 in.

Date Revised: June 21, 2022

Page 6 of 13

Project No. G103127034

Version: 02 August 2017

SFT-BC-OP-19I

EFS/BI 120-01 (7 OF 13)



diameter, hex-head concrete or masonry anchors as applicable, and spaced to match the longitudinal pin spacing shown in Figure 1. For gypsum wall, use min. 1/4 in. diameter, hex-head self-drilling screws, spaced to match the longitudinal pin spacing shown in Figure 1. Position the wall anchors nominal 4 in. from the outer surface of the duct insulation (Item 2) for concrete and masonry wall attachment, and nominal 6 in. from outer surface of the duct insulation (Item 2) for steel stud and gypsum wall attachment. Extend the duct insulation min. 1-1/2 in. beyond the anchors. For steel stud and gypsum wall attachment, ensure that studs are positioned in line with the wall anchors.

- vi. Gypsum Anchor Protection Boards: For installation onto steel stud and gypsum wall, use three layers of 6 in. wide, 5/8 in. Type X gypsum board strips, mounted onto the gypsum wall under the duct insulation (Item 2) and adjacent to the wall anchors (Item 2Cvi) as shown in Figure 9. For vertical application, attach the gypsum wall anchor boards with #10 drywall Type G laminating screws spaced 24 in. oc. For horizontal application, attach the gypsum anchor boards with #10 drywall Type S screws into steel studs. Secure the insulation blanket (Item 2) to the gypsum wall anchor board using wall anchors (Item 2Cvi) consisting of min. 16 GA, min. 1-1/2 in. wide steel sheet strips and #10 drywall Type G laminating screws, spaced to match the longitudinal pin spacing shown in Figure 1.

Division 07 – Thermal and Moisture Protection
07 21 00 Thermal Protection
07 21 16 Blanket Insulation

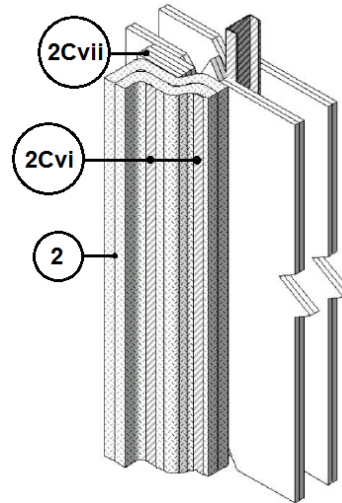

Figure 9. Wall Anchoring

3. **PINS:** Refer to Figure 1. Use this pin-only method for any grease duct (Item 2) size that is approved under this design listing. Use min. 12 GA, 7 in. long, steel insulation pins or min. 12 GA, steel cup-head insulation pins. Weld pins to the grease duct (Item 1) using the pin spacing shown in Figure 1. Use 2-1/2 in. x 2-1/2 in. galvanized steel, self-locking washer clips to secure each layer of insulation (Item 1). After all the clips are installed, cut off or bend flush with duct insulation (Item 1) the pins that are too long.
4. **BANDING:** Use the following banding, or banding and pins, installation method as an approved alternative to pins-only (refer to Item 3) under the conditions noted below:
 - A. **BANDING ONLY METHOD** – Use this alternate method on max. 24 in. x 24 in. grease ducts (Item 1). In lieu of pins, use min. 1/2 in. wide, 0.015 in. thick, stainless steel or carbon steel bands secured with min. 1 in. long steel crimp clamps. When needed to ease installation, use filament tape as a temporary hold for the duct insulation (Item 2) prior to

EFS/BI 120-01 (8 OF 13)

Division 07 – Thermal and Moisture Protection
 07 21 00 Thermal Protection
 07 21 16 Blanket Insulation

banding. After second layer of duct insulation (Item 2) is installed, place banding a max. 2 in. from all duct insulation edges (Item 2) and a max. of 10 in. oc elsewhere. Tension the banding to hold the duct insulation (Item 2) in place without cutting or damaging the duct insulation (Item 2) or grease duct (Item 1).

- B. PIN AND BANDING METHOD – Use this alternate method on max. 36 in. × 36 in. grease ducts (Item 1). For horizontal sections of grease duct (Item 2) only, apply banding as noted in Item 4A and pins as noted in Item 3 on the bottom side of the grease duct (Item 1).
5. **ACCESS DOOR:** May install Intertek Certified, max. 26 in × 20 in. Ductmate Ultimate Access Door™ (not shown), with access door insulation described in Item 5G) for ASTM E2336 only. Additionally, when required by NFPA 96, install an access door using Figure 10a or 10b and the following field-fabricated methods:
- I. **FIELD DOOR 1**
- A. **ACCESS DOOR OPENING** (Not Identified in Figure 10) – Mark a clean-out access opening location on the uninsulated grease duct (Item 1) at its mid-height along the horizontal section. Cut an opening max. 18 in. high × 24 in. wide at the mid-height along the horizontal section. Install 12 GA, 7 in. long, steel insulation pins around the perimeter of the access door opening, spaced 4 in. away from the opening, with a pin located at each corner and max. 10 in. oc elsewhere around the perimeter.
- B. **ACCESS DOOR OPENING FRAME** – Construct a rectangular frame with the same size as the access door opening. Use 1-1/2 in. × 1-1/2 in. × 1/8 in. steel angle with flanges facing outward and with continuously welded and mitered corners. Continuously weld the angle frame to the perimeter of the

access door opening. Drill and tap 3/8-16 threaded holes around the perimeter of the access door frame using max. 6 in. oc spacing.

- C. **DUCT INSULATION OPENING** – Create a stepped opening in the duct insulation layers where the opening in the first layer is cut 1/2 in. smaller than the outside dimensions of the access door opening frame, so that the duct insulation (Item 2) extends under the frame by 1/4 in. around the perimeter. Cut the second layer 2 in. larger than the outside dimensions of the access door opening frame so that there is a 1 in. separation from the frame.
- D. **INNER ACCESS DOOR COVER** – Use 16 GA steel sheet cut to the same dimensions as the access door frame (Item 5B). Drill 1/2 in. diameter through holes spaced to match the bolt pattern of the access door frame. Install min. 12 GA, 6 in. long, steel insulation pins on the inside face of the inner access door cover. Space the pins in a uniform pattern, 2 in. from the perimeter and max. 5 in. oc vertically and horizontally. Install two full thickness layers of un-encapsulated Ductz+ core insulation (Item 2). Cut the Ductz+ core insulation (Item 2) to form a tight fit within the access door opening. Secure the Ductz+ core insulation (Item 2) onto the pins with 2-1/2 in. × 2-1/2 in. galvanized steel, self-locking washer clips. Set the inner access door into the access door opening (Item 5A) with the insulated side towards the opening.
- E. **ACCESS DOOR GYPSUM BOARD** – Use 5/8 in. Type X gypsum board cut to match the size and bolt hole pattern of the inner access door cover (Item 5D).
- F. **OUTER ACCESS DOOR COVER** – Create a 16 GA steel pan, size 1/4 in. larger than the access door frame (Item 5B) in both height and width, and 1 in. deep. Form the pan

Date Revised: June 21, 2022

Page 8 of 13

Project No. G103127034

Version: 02 August 2017

SFT-BC-OP-19I

EFS/BI 120-01 (9 OF 13)



from a single sheet of steel and use continuous welds at the corners. Drill 1/2 in. diameter bolt through holes to match the bolt hole pattern on the access door frame (Item 5B). Install the access door gypsum board (Item 5E) onto the outer access door cover, and then install both onto the inner access door cover. Attach these components to the access door frame using 3/8-16 steel bolts and flat washers. Install min. 12 GA, 6 in. long steel insulation pins on the outer access door cover (Item 5F). Space the pins in a uniform pattern, 2 in. from the perimeter and max. 10 in. oc vertically and horizontally.

- G. ACCESS DOOR INSULATION – Install two layers of Ductz+ insulation (Item 2) onto the outer access door cover (Item 5F). Cut the first layer to fit tightly (min. 1/2 in. compression) into the recess in the second layer duct insulation (Item 2) to cover the access door. Cut the second layer min. 6 in. larger in height and width than the filled recess. Install the second layer of access door insulation over the insulation pins using 2-1/2 in. x 2-1/2 in., galvanized steel self-locking washer clips.

Division 07 – Thermal and Moisture Protection
07 21 00 Thermal Protection
07 21 16 Blanket Insulation

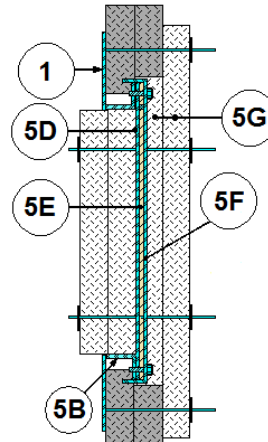

Figure 10a. Access Door

II. FIELD DOOR 2

- H. ACCESS DOOR OPENING (Not Identified in Figure 10b) – Mark a clean-out access opening location on the uninsulated grease duct (Item 1) at its mid-height along the horizontal section. Cut an opening max. 18 in. high x 24 in. wide at the mid-height along the horizontal section. Install 12 GA, 7 in. long, steel insulation pins around the perimeter of the access door opening, spaced 2 in. away from the opening, with a pin located at each corner and max. 4 in. oc elsewhere around the perimeter.
- I. ACCESS DOOR OPENING PERIMETER (Not Identified in Figure 10b) – Drill and tap 3/8-16 threaded holes around the perimeter of the access door frame using max. 6 in. oc spacing on the vertical (left and right) sides, and 4 in. spacing on the horizontal (top and bottom) sides.
- J. DUCT INSULATION OPENING – Create a stepped opening in the duct insulation layers where the opening in the first layer is cut 1 in. larger than the outside dimensions of the

EFS/BI 120-01 (10 OF 13)



access door opening. Cut the second layer 2 in. larger than the outside dimensions of the access door opening frame.

- K. ACCESS DOOR – Use 16 GA steel sheet cut to a door that measures 2 in. wider and higher than the cut dimensions up to a max. 20 in. high × 24 in. wide. Drill 1/2 in. diameter through holes spaced to match the bolt pattern of the access door opening. On the interior face perimeter of the door, install one layer of full thickness un-encapsulated Ductz+ core insulation (Item 2) using silicone. Cut the Ductz+ core insulation (Item 2) to a min. 2 in. wide strip, and attach to the perimeter so a 1/2 in. width extends or overhangs the dimensions of the door. form a tight fit within the access door opening. Secure the Ductz+ core insulation (Item 2) onto the pins with 2-1/2 in. × 2-1/2 in. galvanized steel, self-locking washer clips. Set the inner access door into the access door opening (Item 5A) with the insulated side towards the opening.
- L. ACCESS DOOR INSULATION – Install three layers of Ductz+ insulation (Item 2) onto the access door cover (Item 5K). Cut the first layer to fit tightly (min. 1/2 in. compression) into the recess in the second layer duct insulation (Item 2) to cover the access door. Install the first layer of access door insulation over the insulation pins using 2-1/2 in. × 2-1/2 in., galvanized steel self-locking washer clips. Cut the second layer min. 6 in. larger in height and width than the filled recess. Install the second layer of access door insulation over the insulation pins using 2-1/2 in. × 2-1/2 in., galvanized steel self-locking washer clips. Cut the third layer min. 6 in. larger in height and width than the second layer. Install the third layer of access door insulation over the insulation pins using 2-1/2 in. × 2-1/2 in., galvanized steel self-locking washer clips. Secure the

Division 07 – Thermal and Moisture Protection
07 21 00 Thermal Protection
07 21 16 Blanket Insulation

perimeter of the third layer of access door insulation to duct insulation (Item 2) using aluminum foil tape.

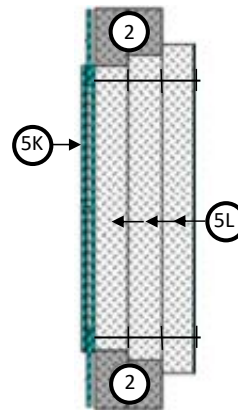

Figure 10b. Access Door

6. **SUPPORTS:** Support the horizontal portion of the insulated grease duct (Item 1) using an un-insulated "trapeze" system composed of a steel angle as the trapeze cross-member and two threaded steel rods connected using nuts and washers. Connect the threaded steel rods to the bottom of the floor assembly using an attachment method designed to carry the weight of the grease duct (Item 1) with duct insulation (Item 2) under a fire load equivalent to that of the ASTM E119 time-temperature curve for the rated period. Place one threaded steel rod at each end of the trapeze cross-member. Center the insulated grease duct (Item 1) on the trapeze cross-member. Space threaded steel rods 1-1/2 in. ± 1/2 in. from surface of the insulated grease duct. Extend trapeze cross-member at least 2 in. past each threaded steel rod. For rectangular grease ducts (Item 1), use min. 1/2 in. diameter, threaded steel rods and min. 3 in. × 3 in. × 1/4 in. steel angle. For round grease ducts (Item 1), use min. 1/2 in. diameter, threaded steel rods and

EFS/BI 120-01 (11 OF 13)

min. 3 in. × 3 in. × 1/4 in. steel angle rings to support the bottom 90° to 180° arc of the grease duct (Item 1). Space the horizontal supports a max. 72 in. oc.

7. FLOOR/CEILING PENETRATION FIRESTOP:

When required to penetrate a fire-rated floor/ceiling assembly, install the firestop system described in Items 7A to 7E (Reference Figure 11).

A. **FLOOR/CEILING ASSEMBLY** – Penetrate a min. 2 hr fire-rated, solid concrete floor/ceiling assembly made from reinforced lightweight or normal weight (100-150-pcf or 1600-2400-kg/m³) concrete, and having a min. thickness of 4.6 in. Create a rectangular or round opening in the floor/ceiling assembly so that the opening width or diameter is 4 in. greater than the outside dimension of the grease duct (Item 1). Use a rectangular hole for rectangular ducts and a round hole for round ducts. Position the grease duct (Item 1) concentrically or eccentrically in the opening so that the annular space is min. 1-1/2 in. to max. 2-1/2 in.

B. **BOTTOM FIRESTOP ANGLES** – Stitch weld 3 in. × 3 in. × 1/4 in. angles to the grease duct (Item 1) on the bottom side of the floor/ceiling assembly along the entire perimeter of the duct. Use two half angle rings of the same size for round ducts. Weld the corners or ends of adjacent angles together.

Division 07 – Thermal and Moisture Protection
07 21 00 Thermal Protection
07 21 16 Blanket Insulation

C. **PACKING MATERIAL** – Fill the annular space between the pre-fabricated grease duct (Item 1) and the floor/ceiling assembly (Item 7A) with un-encapsulated Ductz+ core insulation (Item 2). For each side of the duct, cut multiple strips of insulation a length 1 in. longer than the void space to be filled and 1/4 in. wider than the width of the annular space. Insert the strips into the annular space, one on top of the other, and pressed flat against the 3 in. × 3 in. × 1/4 in. bottom firestop angles (Item 7B) located at the underside of the concrete floor and flush to the top of the floor surface. Use three strips for a 4.6 in. thick concrete floor and one additional strip for every 1-1/2 in. of floor thickness. This represents a min. 32% overall compression.

D. **TOP FIRESTOP ANGLES** – Stitch weld 3 in. × 3 in. × 1/4 in. angles to the grease duct (Item 1) on the top side of the floor/ceiling assembly along the entire perimeter of the duct. Use two half angle rings of the same size for round ducts. Weld the corners or ends of adjacent angles together.

E. **FIRESTOP COLLARS** – Install two layers of 6 in. wide Ductz+ insulation (Item 2) collars around the insulated duct both at the topside and underside of the concrete floor/ceiling assembly. Use min. 3 in. overlaps at the collar ends. Secure the bottom collars with one 1/2 in. wide, 0.015 in. thick, stainless steel or carbon steel band (Item 4). Secure the top collars with aluminum foil tape.

EFS/BI 120-01 (12 OF 13)



Division 07 – Thermal and Moisture Protection
 07 21 00 Thermal Protection
 07 21 16 Blanket Insulation

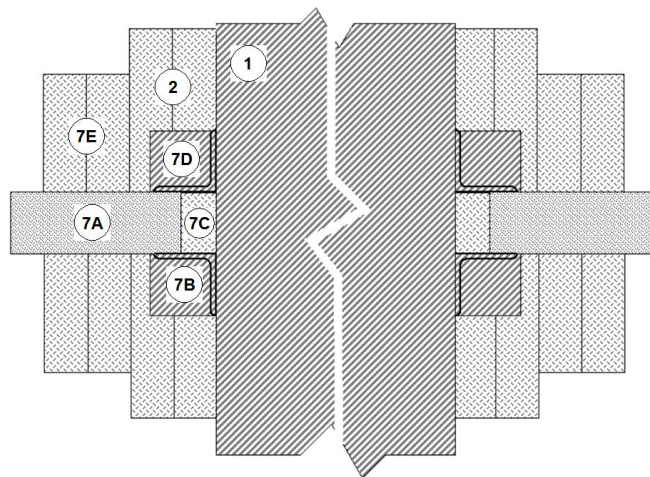

Figure 11: Floor/Ceiling Firestop

- 8. WALL PENETRATION FIRESTOP:** When required to penetrate a fire-rated wall assembly, install the firestop system described in Items 8A to 8D (Reference Figure 12).
- A. WALL ASSEMBLY –** Penetrate a min. 2 hr fire-rated, solid concrete wall assembly made from reinforced lightweight or normal weight (100-150-pcf or 1600-2400 kg/m³) concrete, or a min. 2 hr fire-rated, concrete masonry unit wall; use wall assemblies having a min. thickness of 4.6 in. Create a rectangular or round opening in the wall assembly so that the opening width or diameter is 4 in. greater than the outside dimension of the grease duct (Item 1). Use a rectangular hole for rectangular ducts and a round hole for round ducts. Use solid block to frame the opening or apply concrete mortar to create a solid opening perimeter. Position the grease duct (Item 1) concentrically or eccentrically in the opening so that the annular space is min. 1-1/2 in. to max. 2-1/2 in.
- B. FIRESTOP ANGLES –** Stitch weld 3 in. × 3 in. × 1/4 in. angles to the grease duct (Item 1) on both sides of the wall assembly along the entire perimeter of the duct. Use two half angle rings of the same size for round ducts. Weld the corners or ends of adjacent angles together. Install the firestop angles on one side, then install the firestop angles on the other side after the packing material (Item 8C) is installed.
- C. PACKING MATERIAL –** Fill the annular space between the pre-fabricated grease duct (Item 1) and the wall assembly (Item 8A) with unencapsulated Ductz+ core insulation (Item 2). For each side of the duct, cut multiple strips of insulation a length 1 in. longer than the void space to be filled and 1/4 in. wider than the width of the annular space. Insert the strips into the annular space, one behind the other, and pressed flat against the 3 in. × 3 in. × 1/4 in. bottom firestop angles (Item 8B) located at the opposite side of the wall assembly and flush to the wall surface. Use three strips for a 4.6 in. thick wall and one additional strip for

Date Revised: June 21, 2022

Page 12 of 13

Project No. G103127034

Version: 02 August 2017

SFT-BC-OP-19I

EFS/BI 120-01 (13 OF 13)



Division 07 – Thermal and Moisture Protection
 07 21 00 Thermal Protection
 07 21 16 Blanket Insulation

every 1-1/2 in. of floor thickness. This represents a min. 32% overall compression.

- D. FIRESTOP COLLARS – Install two layers of 6 in. wide Ductz+ insulation (Item 2) collars

around the insulated duct on both sides of the wall assembly. Use min. 3 in. overlaps at the collar ends. Secure each set of collars with one 1/2 in. wide, 0.015 in. thick, stainless steel or carbon steel band (Item 4).

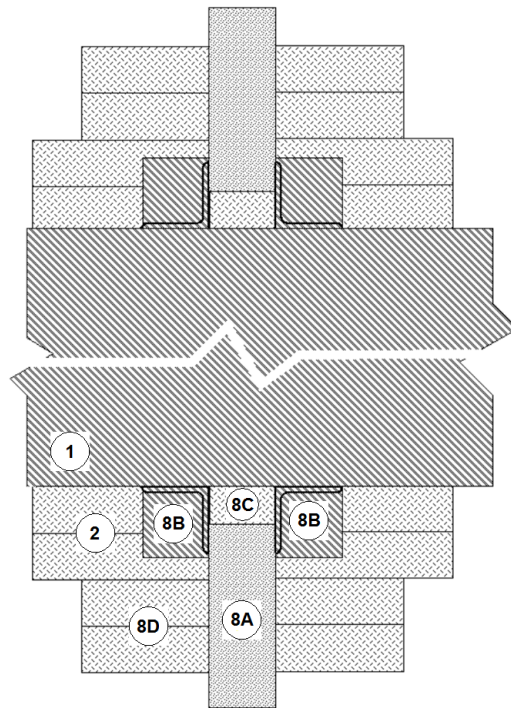

Figure 12. Wall Firestop

Consult the listing report on the Directory of Building Products (<https://bpdirectory.intertek.com>) for the edition of the standard(s) evaluated.

Compliance of the assembly described in this Design Listing with the referenced standard relies on verification that the assembly constructed in the field is consistent with that described herein. Intertek certified products may be verified by the approved Intertek label; other products must be verified by the Authority Having Jurisdiction as meeting the specifications stated herein.

EFS/BI 120-02



Division 07 – Thermal and Moisture Protection
 07 21 00 Thermal Protection
 07 21 16 Blanket Insulation

EFS Engineering Ltd.
Design No. EFS/BI 120-02
FIRE RESISTANT GREASE DUCT
Ductz+, EFS Wrap, FlameWrap, and Model 1.2
ASTM E2336

Non-combustibility Test (ASTM E136): Pass
 Fire Resistance Test (ASTM E119): 2 Hour
 Durability Test (ASTM C518 modified): Pass
 Internal Fire Test – 4 Hour @ 500°F and 30 Minutes @ 2000°F: Pass
 Fire-Engulfment Test (ASTM E119 Exposure): 2 Hour

UL 2221
 Internal Fire Test, Condition A: Pass
 Fire-Engulfment Test: 2 Hour

CAN/ULC-S144
 Rating: 2 Hour
ASTM E814 and UL 1479

F-, T-Rating: 2 Hour
CAN/ULC-S115
 F-, FT-, FH-, FTH-Rating: 2 Hour

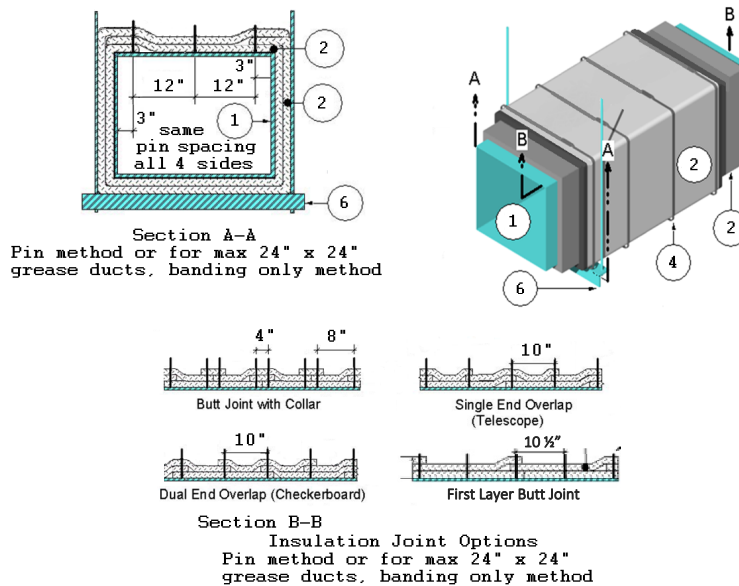

Figure 1. EFS Ductz+ Grease Duct Insulation System

EFS/BI 120-02 (2 OF 13)



Division 07 – Thermal and Moisture Protection
07 21 00 Thermal Protection
07 21 16 Blanket Insulation

1. GREASE DUCT: Use a continuously welded, liquid-tight, rectangular or round duct system with horizontal and vertical shafts constructed to the following min. requirements:

- A. STEEL – Min. 16 GA carbon steel
- B. JOINTS – Continuously welded, liquid-tight construction
- C. CROSS-SECTIONAL SHAPE – Rectangular or Round
- D. CROSS-SECTIONAL DIMENSIONS –
 - i. Rectangular: Max. 54 in. x 54 in.
 - ii. Round: Max. 54 in. diameter
- E. When required, equip the duct with an access door (Item 5)
- F. Reinforce the grease duct to NFPA 96 requirements designed to carry the weight of the grease duct assembly covered with two layers of duct insulation (Item 2) under a fire load equivalent to that of the ASTM E119 time-temperature curve for the rated period.
- G. Rigidly support the grease duct as specified in Item 6 or in accordance with International Mechanical Code (IMC), NFPA 96, or other applicable requirements, when not specified herein or when those requirements are greater.

2. CERTIFIED MANUFACTURER: EFS Engineering Ltd.

CERTIFIED PRODUCT: Duct Insulation

CERTIFIED MODEL: Ductz+, EFS Wrap, and FlameWrap Model 1.2 (Ductz+ used as example in design listing)

Apply two layers of the nominal 1-1/2 in. thick, nominal 6 pcf density duct insulation over the entire surface of the grease duct (Item 1).

- A. STANDARD INSTALLATION – Apply both layers of duct insulation with transverse and longitudinal joints as shown in Figure 1. For

rectangular grease ducts (Item 1), locate inner layer longitudinal joints (Figure 1) at a corner of the grease duct (Item 1), and offset the outer layer joint (Figure 1) to a different corner. For horizontal sections, ensure the longitudinal joints are placed at the top corners. For round grease ducts (Item 1), locate inner layer longitudinal joints and outer layer longitudinal joints 90° apart; for horizontal sections, center the joints on the top of the grease duct (Item 1). Use a min. 4 in. overlap at all insulation joints. Optional: for rectangular ducts only, compressed butt joints may be used on the first layer and horizontal sections only. Transverse butt joints with collar shall use a min. 8 in. wide collar with min. 4 in. overlap on each side of the butt joint. Use blanket, available in various widths, fully encapsulated with a polypropylene foil scrim. Cover all visually exposed ends and edges of duct insulation with nominal 3 in. wide aluminum foil tape. Tape all joints (inner and outer layers; longitudinal and transverse) with nominal 3 in. wide aluminum foil tape (reference Figure 2). Use aluminum foil tape certified to comply with the following criteria:

- ASTM E84 or UL 723: Flame Spread Index not to exceed 25 and Smoke Developed Index not to exceed 50.
- ASTM C411: No flaming, glowing, or smoking at min. 500°F.



Figure 2: Aluminum Tape Installation Detail at Inner and Outer Layer Insulation Joints (tape shown in blue)

- B. THREE-SIDED INSTALLATION – Refer to Figures 3 and 4.

EFS/BI 120-02 (3 OF 13)



Division 07 – Thermal and Moisture Protection
 07 21 00 Thermal Protection
 07 21 16 Blanket Insulation

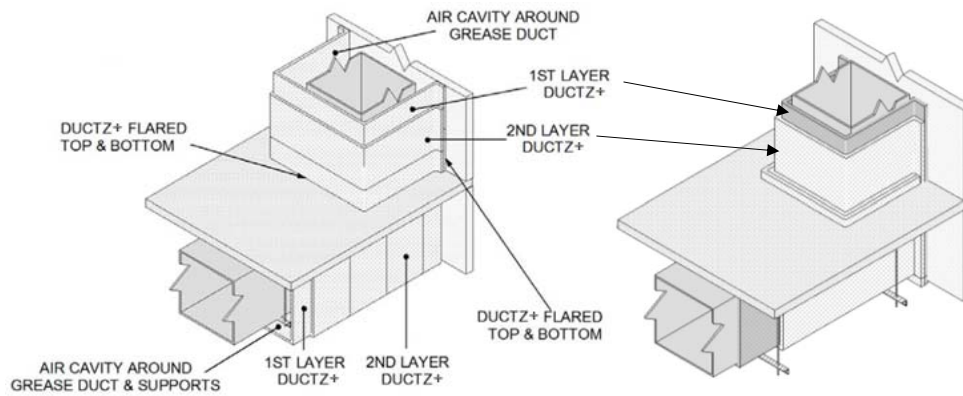

Figure 3. Three-Side Installation Top Isometric (Shown with and without Optional Air Cavity)

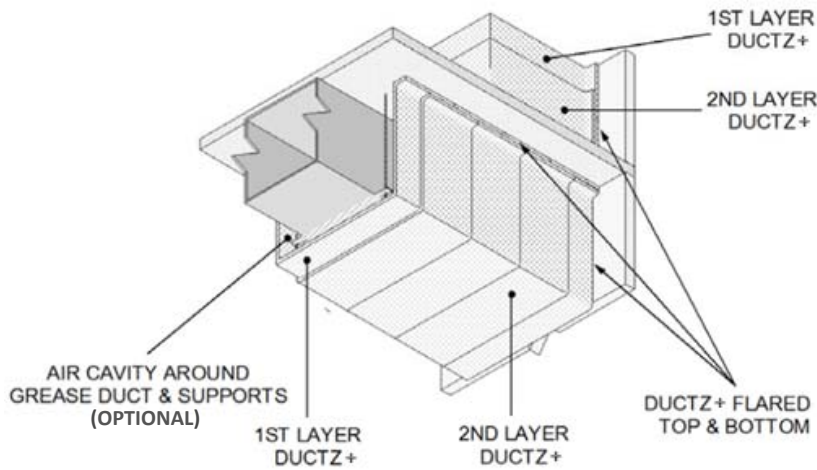

Figure 4. Three-Side Installation Bottom Isometric (Shown with Optional Air Cavity)

When the grease duct (Item 1) is positioned within 12 in. of a 2 hr fire-rated wall or

ceiling, use a three-sided installation method. Apply both layers of duct insulation

EFS/BI 120-02 (4 OF 13)



Division 07 – Thermal and Moisture Protection
 07 21 00 Thermal Protection
 07 21 16 Blanket Insulation

in general accordance with conditions specified in Item 2A with the following additional conditions and modifications:

- i. Floor/Ceiling Assembly: Min. 2 hr fire-rated, reinforced concrete.
- ii. Wall Assembly: Min. 2 hr fire-rated, reinforced concrete; min. 2 hr fire-rated concrete masonry unit (CMU); min. 2 hr fire-rated, steel stud framing with min. two layers of 5/8 in., Type X gypsum board on each side.
- iii. Supports: Position horizontal supports (Item 6) inside of the duct insulation (Item 2), or on the outside of the duct insulation (Item 2). For installation of supports inside the insulated space, apply a min. 6 in. wide strip of un-encapsulated duct insulation (Item 2) between the grease duct (Item 1) and the horizontal supports (Item 6); and space the supporting threaded steel rods 1-1/2 in. ± 1/2 in. from the surface of the uninsulated grease duct.
- iv. Insulation Anchors: Floor/Ceiling Application – Use min. 16 GA, min. 1-1/2 in.-wide steel sheet strips, and min. 1/4 in. diameter hex-head concrete anchors, spaced to match the longitudinal pin spacing shown in Figure 1. Position the floor/ceiling anchors over a min. 6 in. wide horizontal flange of the flared duct insulation (Item 2) which is in contact with the floor/ceiling assembly. Position the anchors such that the duct insulation extends a min. 1-1/2 in. beyond the anchors. Refer to Figure 6.
- v. Insulation Anchors: Wall Application – Use min. 16 GA, min. 1-1/2 in. wide steel sheet strips. For concrete or masonry wall, fasten the duct insulation (Item 2) to the wall using min. 1/4 in. diameter, hex-head concrete or masonry anchors as applicable, and spaced to match the longitudinal pin spacing shown in Figure 1.
- vi. Gypsum Anchor Protection Boards: For installation onto steel stud and gypsum wall, use three layers of 6 in. wide, 5/8 in. Type X gypsum board strips, mounted vertically onto the gypsum wall under the duct insulation (Item 2) and adjacent to the wall anchors (Item 2Bvi) as shown in Figure 6. Attach the gypsum wall anchor boards with #10 drywall Type G laminating screws spaced 24 in. on center (oc). Secure the insulation blanket (Item 2) to the gypsum wall anchor board using wall anchors (Item 2Bvi) consisting of min. 16 GA, min. 1-1/2 in. wide steel sheet strips and #10 drywall Type G laminating screws spaced to match the longitudinal pin spacing shown in Figure 1.

For gypsum wall, use min. 1/4 in. diameter hex-head self-drilling screws spaced to match the longitudinal pin spacing shown in Figure 1. Position the wall anchors over a min. 6 in. wide flange of the flared duct insulation (Item 2) which is in contact with the wall assembly. Position the anchors such that the duct insulation extends a min. 1-1/2 in. beyond the anchors. Refer to Figure 6. For steel stud and gypsum wall attachment, ensure that studs are positioned in line with the wall anchors.

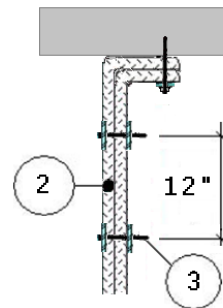

EFS/BI 120-02 (5 OF 13)



Division 07 – Thermal and Moisture Protection
07 21 00 Thermal Protection
07 21 16 Blanket Insulation

Figure 5. Pin Method for Duct Insulation to Floor/Ceiling or Wall for Three-Sided and Two-Sided Installation for Round Ducts

C. TWO-SIDED INSTALLATION – Refer to Figures 7 and 8.

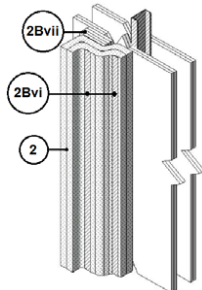

Figure 6. Wall Anchoring

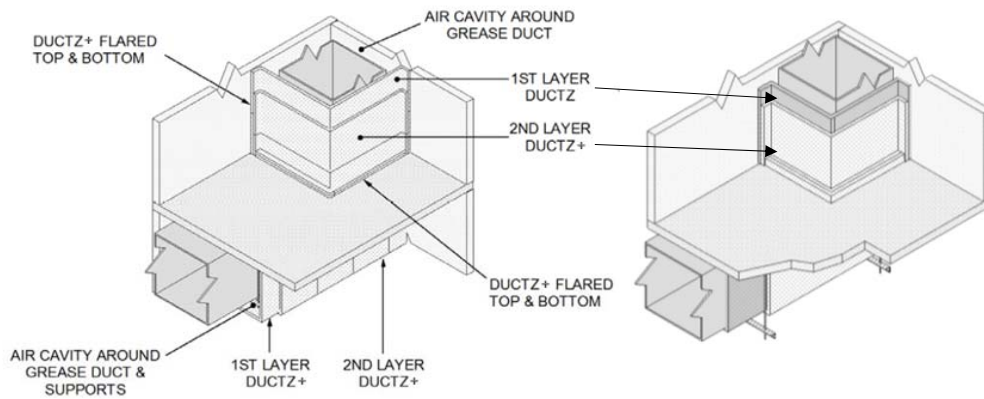

Figure 7. Two-Side Installation Top Isometric (Shown with and without Optional Air Cavity)

EFS/BI 120-02 (6 OF 13)



Division 07 – Thermal and Moisture Protection
 07 21 00 Thermal Protection
 07 21 16 Blanket Insulation

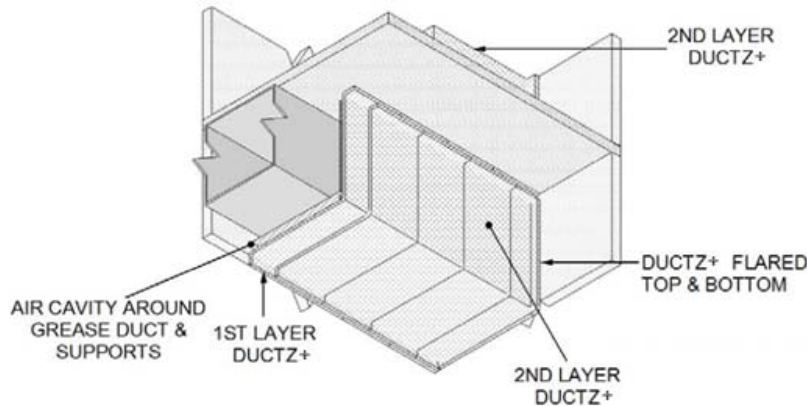

Figure 8. Two-Side Installation Bottom Isometric (Shown with Optional Air Cavity)

When the grease duct (Item 1) is positioned within 12 in. of a 2 hr fire-rated wall and ceiling, or within 12 in. of two adjacent 2 hr fire-rated walls, use a two-sided installation method. Apply both layers of duct insulation in general accordance with conditions specified in Item 2A with the following additional conditions and modifications:

- i. Floor/Ceiling Assembly: Min. 2 hr fire-rated, reinforced concrete.
- ii. Wall Assembly: Min. 2 hr fire-rated, reinforced concrete; min. 2 hr fire-rated concrete masonry unit (CMU); min. 2 hr fire-rated steel stud framing, and min. two layers of 5/8 in. Type X gypsum board on each side.
- iii. Supports: Position horizontal supports (Item 6) inside of the duct insulation (Item 2) or on the outside of the duct insulation (Item 2). For installation of supports inside the insulated space, apply a min. 6 in. wide strip of unencapsulated duct insulation (Item 2) between the grease duct (Item 1) and the horizontal supports (Item 6); and space the supporting threaded steel rods 1-1/2 in. \pm 1/2 in. from the surface of the uninsulated grease duct. For installation on the outside of the duct insulation (Item 2), anchor the wall-facing side of the supports (Item 6) to the wall using min. 3 in. \times 3 in. \times 1/4 in. steel angle. Fasten the brackets to the wall with a min. of two 1/4 in. diameter steel fasteners of the appropriate type for the wall construction. In the case of steel stud wall construction, fasten the brackets into steel studs. When the supports (Item 6) are located outside of the duct insulation (Item 2), install the brackets over the flared duct insulation (Item 2). Fasten the support (Item 6) to the bracket using a 1/2 in. steel bolt, nut and washer.
- iv. Insulation Anchors: Floor/Ceiling Application – Use min. 16 GA, min. 1-1/2 in. wide steel sheet strips, and min. 1/4 in. diameter hex-head concrete anchors, spaced to match the longitudinal pin spacing shown in Figure 1. Position the floor/ceiling anchors nominal 4 in. from the outer surface of the duct insulation (Item 2). Extend the duct insulation min. 1-1/2 in. beyond the anchors. Reference Figure 9.
- v. Insulation Anchors: Wall Application – Use min. 16 GA, min. 1-1/2 in. wide steel sheet strips.

Date Revised: June 21, 2022

Page 6 of 13

Project No. G103127034

Version: 02 August 2017

SFT-BC-OP-19I

EFS/BI 120-02 (7 OF 13)



For concrete or masonry wall, fasten the duct insulation (Item 2) to the wall using min. 1/4 in. diameter, hex-head concrete or masonry anchors as applicable, and spaced to match the longitudinal pin spacing shown in Figure 1. For gypsum wall, use min. 1/4 in. diameter, hex-head self-drilling screws, spaced to match the longitudinal pin spacing shown in Figure 1. Position the wall anchors nominal 4 in. from the outer surface of the duct insulation (Item 2) for concrete and masonry wall attachment and nominal 6 in. from outer surface of the duct insulation (Item 2) for steel stud and gypsum wall attachment. Extend the duct insulation min. 1-1/2 in. beyond the anchors. For steel stud and gypsum wall attachment, ensure that studs are positioned in line with the wall anchors.

- vi. **Gypsum Anchor Protection Boards:** For installation onto steel stud and gypsum wall, use three layers of 6 in. wide, 5/8 in. Type X gypsum board strips mounted onto the gypsum wall under the duct insulation (Item 2) and adjacent to the wall anchors (Item 2Cvi) as shown in Figure 9. For vertical application, attach the gypsum wall anchor boards with #10 drywall Type G laminating screws spaced 24 in. oc. For horizontal application, attach the gypsum anchor boards with #10 drywall Type S screws into steel studs. Secure the insulation blanket (Item 2) to the gypsum wall anchor board using wall anchors (Item 2Cvi) consisting of min. 16 GA, min. 1-1/2 in. wide steel sheet strips and #10 drywall Type G laminating screws spaced to match the longitudinal pin spacing shown in Figure 1.

Division 07 – Thermal and Moisture Protection
07 21 00 Thermal Protection
07 21 16 Blanket Insulation

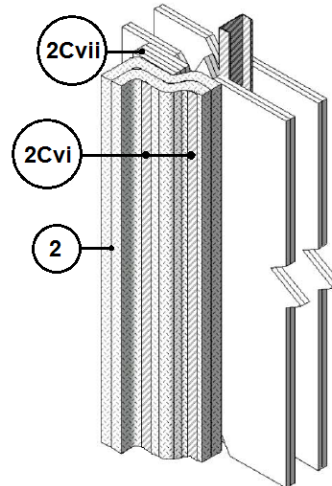

Figure 9. Wall Anchoring

3. **PINS:** Refer to Figure 1. Use this pin-only method for any grease duct (Item 2) size that is approved under this design listing. Use min. 12 GA, 7 in.-long, steel insulation pins or min. 12 GA, steel cup-head insulation pins. Weld pins to the grease duct (Item 1) using the pin spacing shown in Figure 1. Use 2-1/2 in. x 2-1/2 in. galvanized steel, self-locking washer clips to secure each layer of insulation (Item 1). After all the clips are installed, cut off or bend flush with duct insulation (Item 1) the pins that are too long.
4. **BANDING:** Use the following banding, or banding and pins, installation method as an approved alternative to pins-only (refer to Item 3) under the conditions noted below:
 - A. **BANDING ONLY METHOD** – Use this alternate method on max. 24 in. x 24 in. grease ducts (Item 1). In lieu of pins, use min. 1/2 in. wide, 0.015 in. thick, stainless steel or carbon steel bands secured with min. 1 in. long steel crimp clamps. When needed to ease installation, use filament tape as a temporary hold for the duct insulation (Item 2) prior to

EFS/BI 120-02 (8 OF 13)



banding. After second layer of duct insulation (Item 2) is installed, place banding a max. 2 in. from all duct insulation edges (Item 2) and a max. of 10 in. oc elsewhere. Tension the banding to hold the duct insulation (Item 2) in place without cutting or damaging the duct insulation (Item 2) or grease duct (Item 1).

- B. PIN AND BANDING METHOD – Use this alternate method on max. 36 in. × 36 in. grease ducts (Item 1). For horizontal sections of grease duct (Item 2) only, apply banding as noted in Item 4A and pins as noted in Item 3 on the bottom side of the grease duct (Item 1).

5. **ACCESS DOOR:** May install Intertek Certified, max. 26 in × 20 in. Ductmate Ultimate Access Door™ (not shown), with access door insulation described in Item 5G) for ASTM E2336 only. Additionally, when required by NFPA 96, install an access door using Figure 10a or 10b and the following field-fabricated methods:

I. **FIELD DOOR 1**

- A. **ACCESS DOOR OPENING** (Not Identified in Figure 10) – Mark a clean-out access opening location on the uninsulated grease duct (Item 1) at its mid-height along the horizontal section. Cut an opening max. 18 in. high × 24 in. wide at the mid-height along the horizontal section. Install 12 GA, 7 in. long, steel insulation pins around the perimeter of the access door opening, spaced 4 in. away from the opening, with a pin located at each corner and max. 10 in. oc elsewhere around the perimeter.
- B. **ACCESS DOOR OPENING FRAME** – Construct a rectangular frame with the same size as the access door opening. Use 1-1/2 in. × 1-1/2 in. × 1/8 in. steel angle with flanges facing outward and with continuously welded and mitered corners. Continuously weld the angle frame to the perimeter of the

Division 07 – Thermal and Moisture Protection
07 21 00 Thermal Protection
07 21 16 Blanket Insulation

access door opening. Drill and tap 3/8-16 threaded holes around the perimeter of the access door frame using max. 6 in. oc spacing.

- C. **DUCT INSULATION OPENING** – Create a stepped opening in the duct insulation layers where the opening in the first layer is cut 1/2 in. smaller than the outside dimensions of the access door opening frame, so that the duct insulation (Item 2) extends under the frame by 1/4 in. around the perimeter. Cut the second layer 2 in. larger than the outside dimensions of the access door opening frame so that there is a 1 in. separation from the frame.
- D. **INNER ACCESS DOOR COVER** – Use 16 GA steel sheet cut to the same dimensions as the access door frame (Item 5B). Drill 1/2 in. diameter through holes spaced to match the bolt pattern of the access door frame. Install min. 12 GA, 6 in. long, steel insulation pins on the inside face of the inner access door cover. Space the pins in a uniform pattern, 2 in. from the perimeter and max. 5 in. oc vertically and horizontally. Install two full thickness layers of un-encapsulated Ductz+ core insulation (Item 2). Cut the Ductz+ core insulation (Item 2) to form a tight fit within the access door opening. Secure the Ductz+ core insulation (Item 2) onto the pins with 2-1/2 in. × 2-1/2 in. galvanized steel, self-locking washer clips. Set the inner access door into the access door opening (Item 5A) with the insulated side towards the opening.
- E. **ACCESS DOOR GYPSUM BOARD** – Use 5/8 in. Type X gypsum board cut to match the size and bolt hole pattern of the inner access door cover (Item 5D).
- F. **OUTER ACCESS DOOR COVER** – Create a 16 GA steel pan, size 1/4 in. larger than the access door frame (Item 5B) in both height and width, and 1 in. deep. Form the pan

Date Revised: June 21, 2022

Page 8 of 13

Project No. G103127034

Version: 02 August 2017

SFT-BC-OP-19I

EFS/BI 120-02 (9 OF 13)

from a single sheet of steel and use continuous welds at the corners. Drill 1/2 in. diameter bolt through holes to match the bolt hole pattern on the access door frame (Item 5B). Install the access door gypsum board (Item 5E) onto the outer access door cover, and then install both onto the inner access door cover. Attach these components to the access door frame using 3/8-16 steel bolts and flat washers. Install min. 12 GA, 6 in. long steel insulation pins on the outer access door cover (Item 5F). Space the pins in a uniform pattern, 2 in. from the perimeter and max. 10 in. oc vertically and horizontally.

- G. ACCESS DOOR INSULATION – Install two layers of Ductz+ insulation (Item 2) onto the outer access door cover (Item 5F). Cut the first layer to fit tightly (min. 1/2 in. compression) into the recess in the second layer duct insulation (Item 2) to cover the access door. Cut the second layer min. 6 in. larger in height and width than the filled recess. Install the second layer of access door insulation over the insulation pins using 2-1/2 in. x 2-1/2 in., galvanized steel self-locking washer clips.

Division 07 – Thermal and Moisture Protection
07 21 00 Thermal Protection
07 21 16 Blanket Insulation

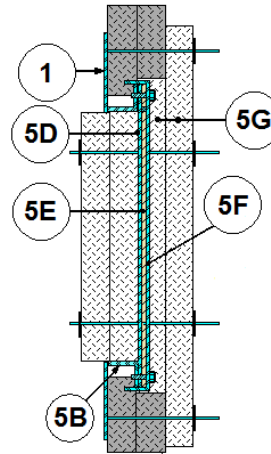

Figure 10a. Access Door

II. FIELD DOOR 2

- H. ACCESS DOOR OPENING (Not Identified in Figure 10b) – Mark a clean-out access opening location on the uninsulated grease duct (Item 1) at its mid-height along the horizontal section. Cut an opening max. 18 in. high x 24 in. wide at the mid-height along the horizontal section. Install 12 GA, 7 in. long, steel insulation pins around the perimeter of the access door opening, spaced 2 in. away from the opening, with a pin located at each corner and max. 4 in. oc elsewhere around the perimeter.
- I. ACCESS DOOR OPENING PERIMETER (Not Identified in Figure 10b) – Drill and tap 3/8-16 threaded holes around the perimeter of the access door frame using max. 6 in. oc spacing on the vertical (left and right) sides, and 4 in. spacing on the horizontal (top and bottom) sides.
- J. DUCT INSULATION OPENING – Create a stepped opening in the duct insulation layers where the opening in the first layer is cut 1 in. larger than the outside dimensions of the

EFS/BI 120-02 (10 OF 13)



access door opening. Cut the second layer 2 in. larger than the outside dimensions of the access door opening frame.

- K. ACCESS DOOR – Use 16 GA steel sheet cut to a door that measures 2 in. wider and higher than the cut dimensions up to a max. 20 in. high × 24 in. wide. Drill 1/2 in. diameter through holes spaced to match the bolt pattern of the access door opening. On the interior face perimeter of the door, install one layer of full thickness un-encapsulated Ductz+ core insulation (Item 2) using silicone. Cut the Ductz+ core insulation (Item 2) to a min. 2 in. wide strip, and attach to the perimeter so a 1/2 in. width extends or overhangs the dimensions of the door. form a tight fit within the access door opening. Secure the Ductz+ core insulation (Item 2) onto the pins with 2-1/2 in. × 2-1/2 in. galvanized steel, self-locking washer clips. Set the inner access door into the access door opening (Item 5A) with the insulated side towards the opening.
- L. ACCESS DOOR INSULATION – Install three layers of Ductz+ insulation (Item 2) onto the access door cover (Item 5K). Cut the first layer to fit tightly (min. 1/2 in. compression) into the recess in the second layer duct insulation (Item 2) to cover the access door. Install the first layer of access door insulation over the insulation pins using 2-1/2 in. × 2-1/2 in., galvanized steel self-locking washer clips. Cut the second layer min. 6 in. larger in height and width than the filled recess. Install the second layer of access door insulation over the insulation pins using 2-1/2 in. × 2-1/2 in., galvanized steel self-locking washer clips. Cut the third layer min. 6 in. larger in height and width than the second layer. Install the third layer of access door insulation over the insulation pins using 2-1/2 in. × 2-1/2 in., galvanized steel self-locking washer clips. Secure the

Division 07 – Thermal and Moisture Protection
 07 21 00 Thermal Protection
 07 21 16 Blanket Insulation

perimeter of the third layer of access door insulation to duct insulation (Item 2) using aluminum foil tape.

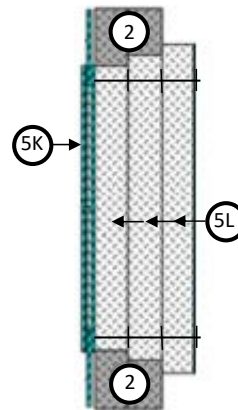

Figure 10b. Access Door

- 6. SUPPORTS: Support the horizontal portion of the insulated grease duct (Item 1) using an un-insulated "trapeze" system composed of a steel angle as the trapeze cross-member and two threaded steel rods connected using nuts and washers. Connect the threaded steel rods to the bottom of the floor assembly using an attachment method designed to carry the weight of the grease duct (Item 1) with duct insulation (Item 2) under a fire load equivalent to that of the ASTM E119 time-temperature curve for the rated period. Place one threaded steel rod at each end of the trapeze cross-member. Center the insulated grease duct (Item 1) on the trapeze cross-member. Space threaded steel rods 1-1/2 in. ± 1/2 in. from surface of the insulated grease duct. Extend trapeze cross-member at least 2 in. past each threaded steel rod. For rectangular grease ducts (Item 1), use min. 1/2 in. diameter, threaded steel rods and min. 3 in. × 3 in. × 1/4-in. steel angle. For round grease ducts (Item 1), use min. 1/2 in. diameter, threaded steel rods and

EFS/BI 120-02 (11 OF 13)

min. 3 in. × 3 in. × 1/4 in. steel angle rings to support the bottom 90° to 180° arc of the grease duct (Item 1). Space the horizontal supports a max. 72 in. oc.

7. FLOOR/CEILING PENETRATION FIRESTOP:

When required to penetrate a fire-rated floor/ceiling assembly, install the firestop system described in Items 7A to 7E (Reference Figure 11).

A. **FLOOR/CEILING ASSEMBLY** – Penetrate a min. 2 hour fire-rated, solid concrete floor/ceiling assembly made from reinforced lightweight or normal weight (100-150-pcf or 1600-2400-kg/m³) concrete, and having a min. thickness of 4.6 in. Create a rectangular or round opening in the floor/ceiling assembly so that the opening width or diameter is 4 in. greater than the outside dimension of the grease duct (Item 1). Use a rectangular hole for rectangular ducts and a round hole for round ducts. Position the grease duct (Item 1) concentrically or eccentrically in the opening so that the annular space is min. 1-1/2 in. to max. 2-1/2 in.

B. **BOTTOM FIRESTOP ANGLES** – Stitch weld 3 in. × 3 in. × 1/4 in. angles to the grease duct (Item 1) on the bottom side of the floor/ceiling assembly along the entire perimeter of the duct. Use two half angle rings of the same size for round ducts. Weld the corners or ends of adjacent angles together.

Division 07 – Thermal and Moisture Protection
07 21 00 Thermal Protection
07 21 16 Blanket Insulation

- C. **PACKING MATERIAL** – Fill the annular space between the pre-fabricated grease duct (Item 1) and the floor/ceiling assembly (Item 7A) with un-encapsulated Ductz+ core insulation (Item 2). For each side of the duct, cut multiple strips of insulation a length 1 in. longer than the void space to be filled and 1/4 in. wider than the width of the annular space. Insert the strips into the annular space, one on top of the other, and pressed flat against the 3 in. × 3 in. × 1/4 in. bottom firestop angles (Item 7B) located at the underside of the concrete floor and flush to the top of the floor surface. Use three strips for a 4.6 in. thick concrete floor and one additional strip for every 1-1/2 in. of floor thickness. This represents a min. 32% overall compression.
- D. **TOP FIRESTOP ANGLES** – Stitch weld 3 in. × 3 in. × 1/4 in. angles to the grease duct (Item 1) on the top side of the floor/ceiling assembly along the entire perimeter of the duct. Use two half angle rings of the same size for round ducts. Weld the corners or ends of adjacent angles together.
- E. **FIRESTOP COLLARS** – Install two layers of 6 in. wide Ductz+ insulation (Item 2) collars around the insulated duct both at the topside and underside of the concrete floor/ceiling assembly. Use min. 3 in. overlaps at the collar ends. Secure the bottom collars with one 1/2 in. wide, 0.015 in. thick, stainless steel or carbon steel band (Item 4). Secure the top collars with aluminum foil tape.

EFS/BI 120-02 (12 OF 13)



Division 07 – Thermal and Moisture Protection
07 21 00 Thermal Protection
07 21 16 Blanket Insulation

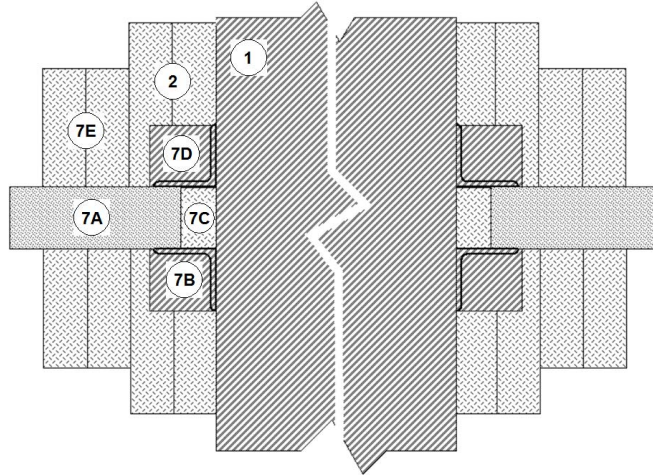

Figure 11: Floor/Ceiling Firestop

- 8. WALL PENETRATION FIRESTOP:** When required to penetrate a fire-rated wall assembly, install the firestop system described in Items 8A to 8D (Reference Figure 12).
- A. **WALL ASSEMBLY** – Penetrate a min. 2 hr fire-rated, solid concrete wall assembly made from reinforced lightweight or normal weight (100-150-pcf or 1600-2400 kg/m³) concrete, or a min. 2 hr fire-rated, concrete masonry unit wall; use wall assemblies having a min. thickness of 4.6 in. Create a rectangular or round opening in the wall assembly so that the opening width or diameter is 4 in. greater than the outside dimension of the grease duct (Item 1). Use a rectangular hole for rectangular ducts and a round hole for round ducts. Use solid block to frame the opening or apply concrete mortar to create a solid opening perimeter. Position the grease duct (Item 1) concentrically or eccentrically in the opening so that the annular space is min. 1-1/2 in. to max. 2-1/2 in.
- B. **FIRESTOP ANGLES** – Stitch weld 3 in. × 3 in. × 1/4 in. angles to the grease duct (Item 1) on both sides of the wall assembly along the entire perimeter of the duct. Use two half angle rings of the same size for round ducts. Weld the corners or ends of adjacent angles together. Install the firestop angles on one side, then install the firestop angles on the other side after the packing material (Item 8C) is installed.
- C. **PACKING MATERIAL** – Fill the annular space between the pre-fabricated grease duct (Item 1) and the wall assembly (Item 8A) with unencapsulated Ductz+ core insulation (Item 2). For each side of the duct, cut multiple strips of insulation a length 1 in. longer than the void space to be filled and 1/4 in. wider than the width of the annular space. Insert the strips into the annular space, one behind the other, and pressed flat against the 3 in. × 3 in. × 1/4 in. bottom firestop angles (Item 8B) located at the opposite side of the wall assembly and flush to the wall surface. Use three strips for a 4.6 in. thick wall and one additional strip for

Date Revised: June 21, 2022

Page 12 of 13

Project No. G103127034

Version: 02 August 2017

SFT-BC-OP-19I

EFS/BI 120-02 (13 OF 13)



Division 07 – Thermal and Moisture Protection
07 21 00 Thermal Protection
07 21 16 Blanket Insulation

every 1-1/2 in. of floor thickness. This represents a min. 32% overall compression.

- D. FIRESTOP COLLARS – Install two layers of 6 in. wide Ductz+ insulation (Item 2) collars around the insulated duct on both sides of

the wall assembly. Use min. 3 in. overlaps at the collar ends. Secure each set of collars with one 1/2 in. wide, 0.015 in. thick, stainless steel or carbon steel band (Item 4).

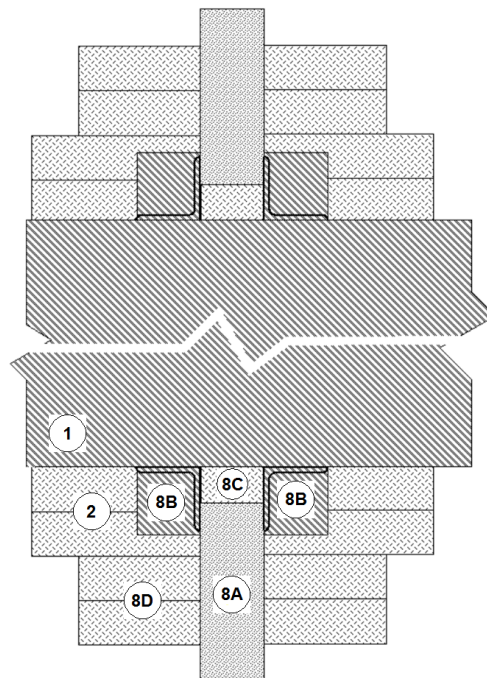

Figure 12. Wall Firestop

Consult the listing report on the Directory of Building Products (<https://bpdirectory.intertek.com>) for the edition of the standard(s) evaluated.

Compliance of the assembly described in this Design Listing with the referenced standard relies on verification that the assembly constructed in the field is consistent with that described herein. Intertek certified products may be verified by the approved Intertek label; other products must be verified by the Authority Having Jurisdiction as meeting the specifications stated herein.

EFS/BI 120-03



Division 23 – Heating, Ventilation, and Air-Conditioning (HVAC)
 23 07 00 HVAC Insulation
 23 07 13 Duct Insulation

EFS Engineering Ltd.
Design No. EFS/BI 120-03
FIRE RESISTANT DUCT
(VERTICAL VENTILATION DUCT)
Ductz+, EFS Wrap, FlameWrap, and Model 1.2
Ductz+, EFS Wrap, FlameWrap, and Model 2.2
ISO 6944 Duct A
Stability – 120 Min
Insulation – 120 Min
Integrity – 120 Min

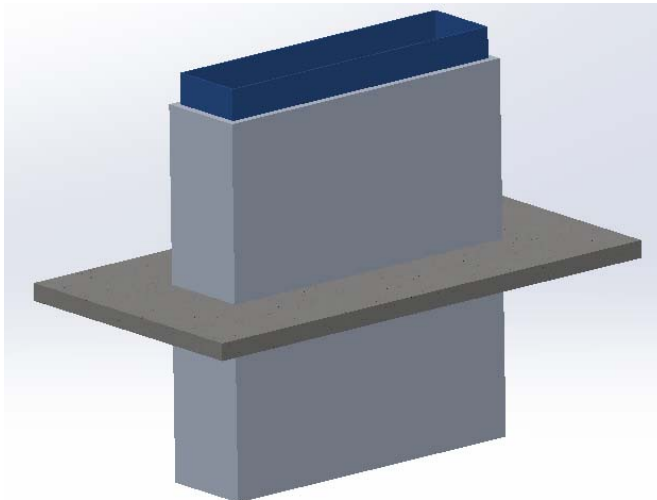

1. **VENTILATION DUCT:** Install a vertically oriented, continuous, air-tight, duct system constructed per SMACNA HVAC Duct Construction Standards, metal and Flexible, Third Edition – 2005 or DW/144, Specification for Sheet Metal Ductwork, Low, Medium, and High Pressure/Velocity Air Systems, 1998 and the requirements for Rectangular Ducts (Item 1A). Position the duct assembly concentrically in the floor assembly's (Item 4) opening. Annular space of 2 in.
 - A. Rectangular Ducts
 - i. Max cross sectional area: 2040 in.²
 - ii. Max width: 85 in.
 - iii. Sheet Steel: Use min. 22 GA galvanized-sheet steel; increase steel GA as needed to meet min. SMACNA or DW/144 requirements for the pressure class and size.
 - iv. Duct Reinforcement: Use min. reinforcement requirements for 2 in. water gauge under pressure; increase as needed to meet min. SMACNA or DW/144 requirements for higher pressure class. SMACNA: Reinforcement Code No. I-22H; Duct Reinforcement H at 24 in. – tie rods (1/4 in. diameter EMT Conduit),

EFS/BI 120-03 (2 OF 3)



Division 23 – Heating, Ventilation, and Air-Conditioning (HVAC)
23 07 00 HVAC Insulation
23 07 13 Duct Insulation

Reinforcement Class H (2 in. × 2 in. × 1/8 in. angle); Transverse Joint Reinforcement DM25 with Tie Rod.

- 2. **INSULATION:** Apply one layer of the nominal 1-1/2 in. thick, nominal 6 pcf density duct insulation over the entire surface of the ventilation duct (Item 1).

CERTIFIED PRODUCT: EFS Engineering Ltd., Duct Insulation; Ductz+, EFS Wrap, and FlameWrap Model 1.2); Ductz+, EFS Wrap, and FlameWrap, Model 2.2 (Ductz+ used as example in design listing).

- A. **STANDARD INSTALLATION** – Apply a layer of duct insulation with min. 4 in. overlap on transverse and longitudinal joints. Use blanket, available in various widths, fully encapsulated with a polypropylene foil scrim. Cover all visually exposed ends and edges of duct insulation with nominal 3 in. wide aluminum foil tape. Tape all joints (inner and outer layers; longitudinal and transverse) with nominal 3 in. wide aluminum foil tape (reference Figure 1). Use aluminum foil tape certified to comply with the following criteria:

- ASTM E84 or UL 723: Flame Spread Index not to exceed 25 and Smoke Developed Index not to exceed 50.
- ASTM C411: No flaming, glowing, or smoking at min. 500°F.



Figure 1: Aluminum Tape Installation Detail at Inner and Outer Layer Insulation Joints (tape shown in blue)

Use min. 1/2 in. wide, 0.015 in. thick, stainless steel or carbon steel bands secured with min. 1 in. long steel crimp clamps. When needed to ease installation, use filament tape as a temporary hold for the duct insulation (Item 2) prior to banding. After a layer of duct insulation (Item 2) is installed, place banding a max. 2 in. from all duct insulation edges (Item 2) and a max. of 10 in. on center (oc) elsewhere. Tension the banding to hold the duct insulation (Item 2) in place without cutting or damaging the duct insulation (Item 2) or duct (Item 1).

- 3. **SUPPORTS:** After installation of the insulation blanket (Item 2) is complete, add a typical support system as required by IMC or SMACNA requirements that will support the load of the ventilation duct and the additional weight of the insulation system under a fire load.
- 4. **FLOOR/CEILING ASSEMBLY:** Use a min. 2-hour fire-rated, solid, 4-5/8 in. thick reinforced lightweight (100 to 150 pcf) concrete floor/ceiling assembly.
- 5. **FIRESTOP SYSTEM:** Create a rectangular opening in the floor/ceiling assembly (Item 4) that maintains a nominal 2 in. annular space. Install a bottom angle (18 GA × 1 in. × 4-1/2 in.) around the underside perimeter of the opening fastened to the concrete slab with 3/16 in. × 1-1/4 in. concrete screws spaced 8 in. oc and fastened to the duct with #12 × 1 in. hex washer head slotted metal screws spaced 8 in. oc. Fill the annular space between the duct (Item 1) and the floor/ceiling assembly (Item 4) with un-encapsulated core insulation (Item 2). Insulation strips are to be 9 in. wide and cut 1 in. longer than the relative length of the space it is to be placed in. Fold the insulation piece in half along the length of the strip and pack into the space. After filling the annular space with insulation,

EFS/BI 120-03 (3 OF 3)



Division 23 – Heating, Ventilation, and Air-Conditioning (HVAC)
 23 07 00 HVAC Insulation
 23 07 13 Duct Insulation

install top perimeter angles in the same manner as the bottom angles. See Figure 2 for details.

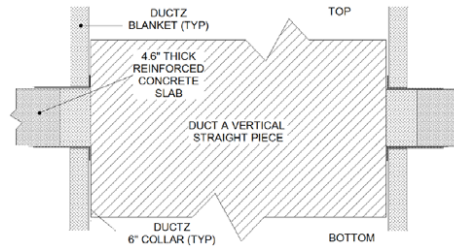

Figure 2: Detail view of Firestop System.

Consult the listing report on the Directory of Building Products (<https://bpdirectory.intertek.com>) for the edition of the standard(s) evaluated.

Compliance of the assembly described in this Design Listing with the referenced standard relies on verification that the assembly constructed in the field is consistent with that described herein. Intertek certified products may be verified by the approved Intertek label; other products must be verified by the Authority Having Jurisdiction as meeting the specifications stated herein.

EFS/BI 90-01



Division 23 – Heating, Ventilation, and Air-Conditioning (HVAC)
 23 07 00 HVAC Insulation
 23 07 13 Duct Insulation

EFS Engineering Ltd.
Design No. EFS/BI 90-01
FIRE RESISTANT DUCT
(Horizontal VENTILATION DUCT)
Ductz+, EFS Wrap, FlameWrap, and Model 1.2
Ductz+, EFS Wrap, FlameWrap, and Model 2.2
ISO 6944 Duct A
Stability – 120 Min
Insulation – 90 Min
Integrity – 120 Min

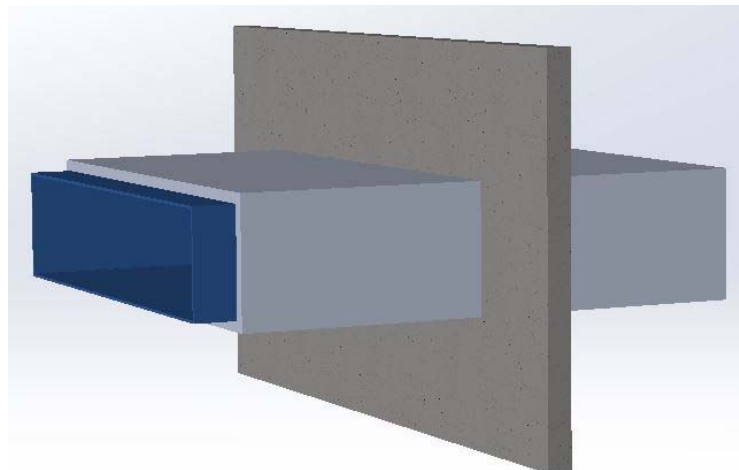

1. **VENTILATION DUCT:** Install a horizontally oriented, continuous, air-tight, duct system constructed per SMACNA HVAC Duct Construction Standards, metal and Flexible, Third Edition – 2005 or DW/144, Specification for Sheet Metal Ductwork, Low, Medium, and High Pressure/Velocity Air Systems, 1998 and the requirements for Rectangular Ducts (Item 1A). Position the duct assembly concentrically in the wall assembly's (Item 4) opening. Annular space of 2 in.
 - A. Rectangular Ducts
 - i. Max cross sectional area: 2040 in.²
 - ii. Max width: 85 in.
 - iii. Sheet Steel: Use min. 22 GA galvanized-sheet steel; increase steel GA as needed to meet min. SMACNA or DW/144 requirements for the pressure class and size.
 - iv. Duct Reinforcement: Use min. reinforcement requirements for 2 in. water gauge under pressure; increase as needed to meet min. SMACNA or DW/144 requirements for higher pressure class. SMACNA: Reinforcement Code No. I-22H; Duct Reinforcement H at 24 in. – tie rods (1/4 in. diameter EMT Conduit), Reinforcement Class H (2 in. × 2 in. × 1/8

Date Issued: January 14, 2022

Page 1 of 4

Spec ID: 46247

Version: 9 June 2021

SFT-BC-OP-19I

EFS/BI 90-01 (2 OF 4)



Division 23 – Heating, Ventilation, and Air-Conditioning (HVAC)
 23 07 00 HVAC Insulation
 23 07 13 Duct Insulation

in. angle); Transverse Joint Reinforcement DM25 with Tie Rod.

2. **INSULATION:** Apply one layer of the nominal 1-1/2 in. thick, nominal 6 pcf density duct insulation over the entire surface of the ventilation duct (Item 1).

CERTIFIED PRODUCT: EFS Engineering Ltd., Duct Insulation; Ductz+, EFS Wrap, and FlameWrap Model 1.2); Ductz+, EFS Wrap, and FlameWrap, Model 2.2 (Ductz+ used as example in design listing).

A. **STANDARD INSTALLATION** – Apply a layer of duct insulation with min. 4 in. overlap on transverse and longitudinal joints. Use blanket, available in various widths, fully encapsulated with a polypropylene foil scrim. Cover all visually exposed ends and edges of duct insulation with nominal 3 in. wide aluminum foil tape. Tape all joints (inner and outer layers; longitudinal and transverse) with nominal 3 in. wide aluminum foil tape (reference Figure 1). Use aluminum foil tape certified to comply with the following criteria:

- ASTM E84 or UL 723: Flame Spread Index not to exceed 25 and Smoke Developed Index not to exceed 50.
- ASTM C411: No flaming, glowing, or smoking at min. 500°F.



Figure 1: Aluminum Tape Installation Detail at Inner and Outer Layer Insulation Joints (tape shown in blue)

Use min. 1/2 in. wide, 0.015 in. thick, stainless steel or carbon steel bands secured with min. 1 in. long steel crimp clamps. When needed to

ease installation, use filament tape as a temporary hold for the duct insulation (Item 2) prior to banding. After a layer of duct insulation (Item 2) is installed, place banding a max. 2 in. from all duct insulation edges (Item 2) and a max. of 9-1/2 in. on center (oc) elsewhere. Tension the banding to hold the duct insulation (Item 2) in place without cutting or damaging the duct insulation (Item 2) or duct (Item 1).

3. **SUPPORTS:** After installation of the insulation blanket (Item 2) is complete, add a typical support system as required by IMC or SMACNA requirements that will support the load of the ventilation duct and the additional weight of the insulation system under a fire load.

Support the horizontal ventilation duct (Item 1) using an uninsulated “Trapeze” Suspension System composed of the following items spaced max. 60 in. oc. Center ventilation duct (Item 1) with duct insulation (Item 2) on steel angle (Item 3A). Extend steel angle (Item 3A) at least 2 in. past each all-thread, steel rod (Item 3B). Refer to Figure 3. At any branch install a support within 12 in. of the main duct and a support centered on any branch turn:

- A. **Steel Angle:**
 - i. **Rectangular Duct Supports:** Use steel angle (Item 3A) as the trapeze cross-member. Steel angle shall be min. 1/4 in. x 3 in. x 3 in. Steel angle shall have holes positioned at a min. of 1 in. to max. 3 in. from the outer surface of the insulated ventilation duct. Holes shall be cut to a diameter corresponding steel rod (Item 3B).
- B. **Steel Rod:** Install two, all-thread, steel rods through holes in the steel angles (Item 3A) connected using washers and nuts. Fingertighten top nut and loosen 1/2 turn. Use min. 1/2 in. all-thread steel rods. Connect the all-thread steel rods (Item 3B) to the bottom of the floor/ceiling assembly (Item

EFS/BI 90-01 (3 OF 4)



Division 23 – Heating, Ventilation, and Air-Conditioning (HVAC)
 23 07 00 HVAC Insulation
 23 07 13 Duct Insulation

4) using attachment methods designed to carry the weight of the ventilation duct (Item 1) with its insulation (Item 2) under a fire load equivalent to that of the ISO 6944 exposure and time-temperature curve for the rated period.

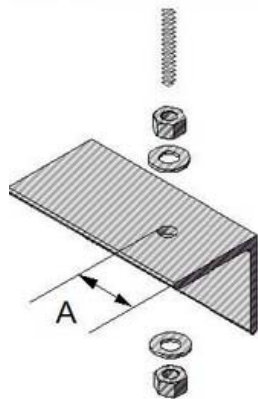

Figure 2: Detail View of Steel Rod Connection.

4. **FLOOR/CEILING ASSEMBLY:** Use a min. 2 hour fire-rated, solid, 4-5/8 in. thick reinforced lightweight (100 to 150 pcf) concrete floor/ceiling assembly.
5. **WALL ASSEMBLY:** Use a min. 2-hour, fire-rated, listed gypsum wall assembly constructed of min. 25 GA, 3-5/8 in. deep, steel C-studs, spaced max. 24 in. oc, with at least two layers of min. 5/8 in. thick, type X gypsum board on each side.
 - A. Create an opening in the wall assembly (Item 5) compatible with the horizontal penetrating item dimensions a nominal 2 in. annular space.
6. **FIRESTOP SYSTEM:** Create a rectangular opening in the wall assembly (Item 5) that maintains a nominal 2 in. annular space. Install a perimeter around the opening on both sides

using min. 18 GA × 3-1/2 in. × 1 in. steel angle. Fasten perimeter to the steel studs and track of the wall (Item 5) with min. #8 × 1 in. hex washer head self-drilling screws spaced 6 in. oc. Fasten perimeter to duct with min. #8 × 1 in. hex washer head self-drilling screws spaced 6 in. oc. After installing a perimeter angle on one side of the wall, fill the annular space between the duct (Item 1) and the wall assembly (Item 5) with un-encapsulated core insulation (Item 2). Insulation strips are to be 13-1/2 in. wide and cut 1 in. longer than the relative length of the space it is to be placed in. Fold the insulation piece in half along the length of the strip and pack into the space. After filling the annular space with insulation, install opposite (exterior) perimeter angles in the same manner as the initial (interior) angles. See Figure 2 for details.

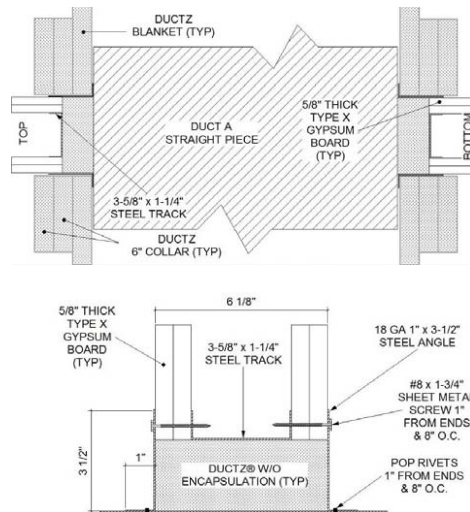

Figure 3: Detail Views of Firestop System.

EFS/BI 90-01 (4 OF 4)



Division 23 – Heating, Ventilation, and Air-Conditioning (HVAC)
23 07 00 HVAC Insulation
23 07 13 Duct Insulation

Consult the listing report on the Directory of Building Products (<https://bpdirectory.intertek.com>) for the edition of the standard(s) evaluated.

Compliance of the assembly described in this Design Listing with the referenced standard relies on verification that the assembly constructed in the field is consistent with that described herein. Intertek certified products may be verified by the approved Intertek label; other products must be verified by the Authority Having Jurisdiction as meeting the specifications stated herein.

Date Issued: January 14, 2022

Page 4 of 4

Spec ID: 46247

Version: 09 June 2021

SFT-BC-OP-19i