

Ref. no.: 500 - 506

Volume flow controller

Self regulating, rectangular

Type VRRK 500 - 506

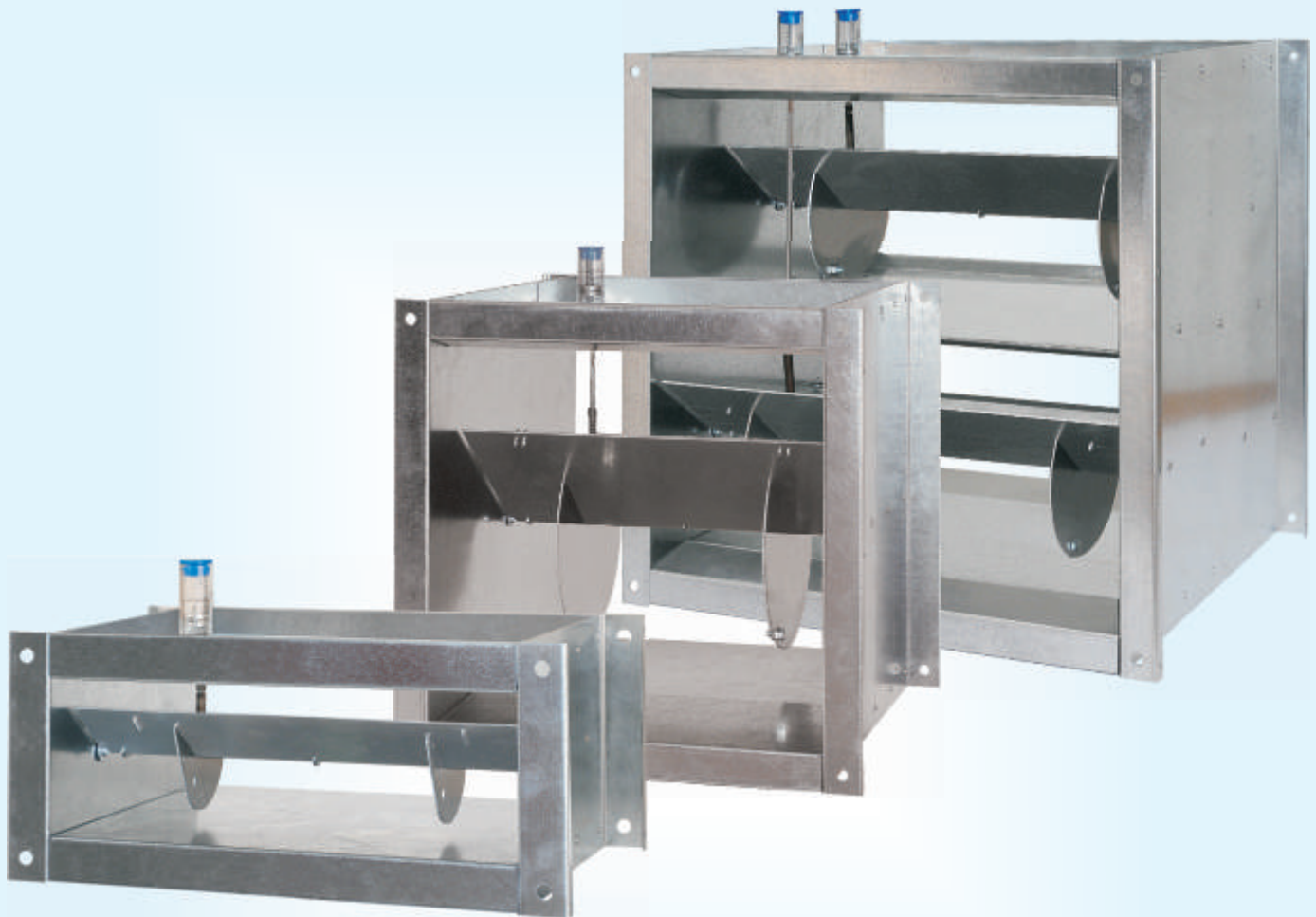

**AEROTECHNIK
SIEGWART**

Aerotechnik E. Siegwart GmbH
Untere Hofwiesen • D-66299 Friedrichsthal
☎ + 49 (0) 6897/859-0 • 📠 +49 (0) 6897/859-150
www.aerotechnik.de • info@aerotechnik.de

Ref. no.: 500 - 506

Constant volume flow controller self regulating - rectangular

Constant volume flow controller (type VRRK)

Range of application: Volume flow controllers type VRRK are used to regulate automatically a required air flow in rectangular ducts. Their task is to keep a default nominal value of the volume flow constantly, lastingly and independently of the varying pressure in the duct.

Operating principle: Constant volume flow controllers work with a smooth-running, asymmetrically angled plate, which guarantees a sensitive responding behaviour even in case of low volume flows.

Pressure, accuracy and scope: The controller operates reliably from a minimum pressure difference, which depends on the air velocity (see diagram 1), to a maximum pressure difference of 1000 Pa. The flow rate variation is usually within a tolerance of $\pm 10\%$. If the air velocity is below 4 m/s or the controller is installed horizontally, variations can be higher as indicated. This will apply also if the air flow profile is not uniform or distorted by bends, sharp edges, bottlenecks or dirt.

Temperature: The components of the controller are largely age-resistant and operate within a temperature range of -30°C up to $+100^{\circ}\text{C}$. A special, heat resistant version for temperatures up to 250°C (briefly even 300°C) is available on request. For volume flow controllers with electric or pneumatic actuators, the operating temperatures of the actuators have to be considered.

Construction: The control plate is supported by two PTFE bearings, which are maintenance-free and smooth-running. One, resp. two pneumatic dampers prevent the control plate from vibrating and oscillating and guarantee a sensitive responding behaviour and a precise control.

Installation: The precise balance of the control plate by a counter weight guarantees an exact control in any installation situation. An undisturbed air flow profile in front of the volume flow controller is recommended because a disturbance (e.g. asymmetrically incoming air flow, bottlenecks or sharp edges) can have negative effects on the responding behaviour and the control.

Adjustment: The volume flow controllers are delivered either with any flow rate required by the customer or with a factory-preset reference flow rate. By an Allen key (2 mm), the flow rate can easily be set or reset in the range of the corresponding scale by the customer. Concerning the twin controllers the summation of the volume flow values on both scales results in the total volume flow rate. On request, the flow rate can also be set by an electric or a pneumatic actuator.

Dimensioning: Before dimensioning a duct system and choosing a certain volume flow controller, it has to be considered that the air velocity in the duct system should be between 3,0 m/s and 10 m/s. The duct just in front and just at the back of the volume flow controller should have the same dimensions (height and width) as the volume flow controller. As reference value or benchmark, an average air velocity around 6,5 m/s is recommended.

ATEX: We manufacture the constant volume flow controller also in explosion-protected execution according to ATEX. Corresponding to the appliance group 2 it is suitable for the gas explosion-protection zones 1 or 2 as well as the dust explosion-protection zones 21 and 22. The controller is marked as follows: II 2GD c IIB80°.

Insulation: The volume flow controllers can be delivered with a 30 mm noise resp. heat insulation. For insulation provided by the customer, the adjusting device resp. the bracket for the electric or pneumatic actuator can be extended. In this case the insulation width has to be specified by the customer.

Installation note: According to DIN 1946 part 2, an accessibility to the volume flow controller and the duct system for maintenance and adjustment has to be taken into consideration. When installing behind redirections or junctions, the free flow section must be at least $2,5 \cdot$ the diagonal.



Aerotechnik E. Siegwart GmbH
Untere Hofwiesen • D-66299 Friedrichsthal
☎ + 49 (0) 6897/859-0 • 📠 +49 (0) 6897/859-150
www.aerotechnik.de • info@aerotechnik.de

Ref. no.: 500 - 506

Constant volume flow controller self regulating - rectangular

Volume flow against duct cross section

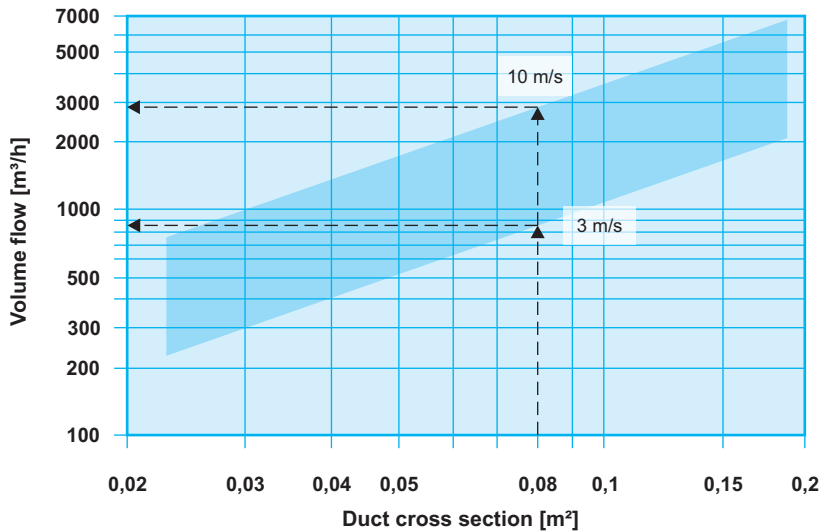

Example:

Given: Volume flow controller
Type VRRK, ref. no. 500
Width 400 mm, height 200 mm
[duct cross section 0,08 m²]

Which volume flow is possible?

Solution according to the chart on the left:

V at 3 m/s = 865 m³/h
V at 10 m/s = 2880 m³/h

Air velocity
between 3 m/s und 10 m/s

Important information:

Generally the regulators do not cover the airflow shown but only a partition.
In case of orders and demands, please do indicate the airflow desired or the airflow range.

Ref. no. 500

- Constant volume flow controller, self regulating
 - Factory-preset reference flow rate according to customer specification
 - Manual setting of the flow rate by adjusting device
 - Variable height and width, constant length
 - Height 100 mm, between 150 mm to 300 mm (to 600 mm, see page 7)
 - Width between 150 mm to 600 mm
 - Connection: 4 holes flange 30 mm
- $H \leq B \leq 2H$

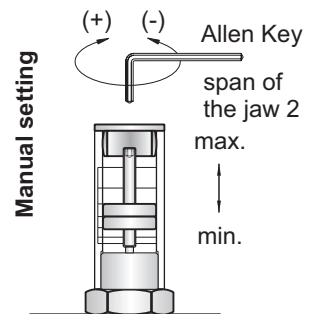
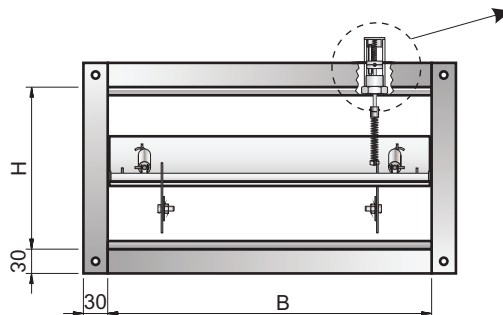
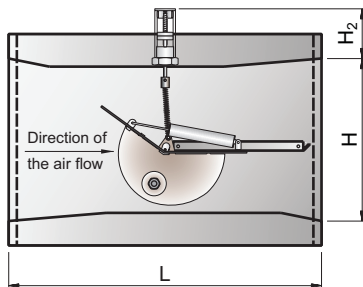

Minimum static pressure difference at the controller

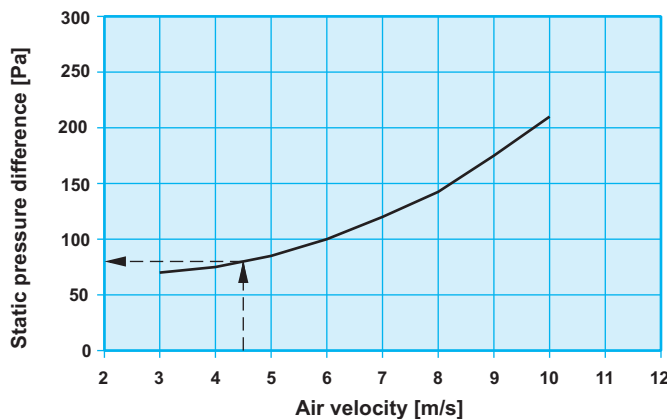

Example:

Given: Volume flow controller
Type VRRK, ref. no. 500
Width 250 mm, height 200 mm
[duct cross section 0,05 m²]
Volume flow 810 m³/h
(= Air velocity 4,5 m/s)

Minimum static pressure difference Δp in Pa?

Solution according to the chart on the left:

$\Delta p = 80 \text{ Pa}$



Aerotechnik E. Siegwart GmbH
Untere Hofwiesen · D-66299 Friedrichsthal
☎ +49 (0) 6897/859-0 · 📠 +49 (0) 6897/859-150
www.aerotechnik.de · info@aerotechnik.de

Ref. no.: 500 - 506

Constant volume flow controller self regulating - rectangular

Pneumatic actuation

Ref. no. 502 Similar to ref. no. 500, factory-preset reference flow rate with variable control by pneumatic actuation, activation by control pressure between 0,2 to 1,0 bar (max. pressure 1,3 bar).
Motor type: **LTG SMA 1** or equal (up to width 250 mm)
ROX or equal (width 251 mm or larger)

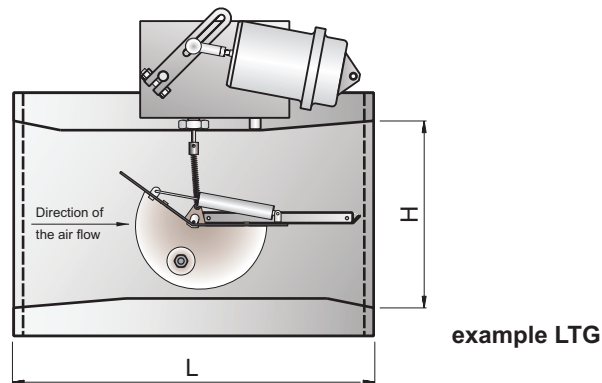

Electric actuation

Ref. no. 503 Similar to ref. no. 500, factory-preset, control by an electric actuator and two set values, operating voltage 230 V, 50 Hz. Controller with two set values without intermediate positions, activation by switches.
Motor type: **Belimo LM 230A** or equal (up to width 250 mm)
Belimo NM 230A or equal (width 251 mm or larger)

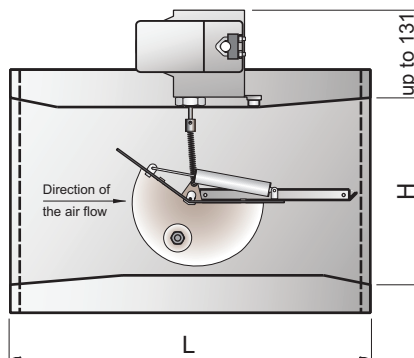

Ref. no. 504: Similar to ref. no. 503, additional auxiliary switch for activation of an additional switching command.
Motor type: **Belimo LM 230A-S** or equal (up to width 250 mm)
Belimo NM 230A-S or equal (width 251 mm or larger)

Ref. no. 505: Similar to ref. no. 503, operating voltage AC 24 V, 50/60 Hz or DC 24 V.
Motor type: **Belimo LM 24A** or equal (up to width 250 mm)
Belimo NM 24A or equal (width 251 mm or larger)

Ref. no. 506: Similar to ref. no. 503, variable control by electric adjustment, operating voltage AC 24 V, 50/60 Hz or DC 24 V, activation by input signal between 2 and 10 V DC.
Motor type: **Belimo LM 24A-MF** or equal (up to width 250 mm)
Belimo NM 24A-MF or equal (width 251 mm or larger)



Aerotechnik E. Siegwart GmbH
Untere Hofwiesen · D-66299 Friedrichsthal
☎ + 49 (0) 6897/859-0 · 📠 + 49 (0) 6897/859-150
www.aerotechnik.de · info@aerotechnik.de

Constant volume flow controller self regulating - rectangular

Table 1: Flow noise

Width [mm]	Height [mm]	Velocity [m/s]	Volume flow [m³/h]	Static pressure difference at the controller [Pa]																										
				100 Pa								Summation L _{w(eq)A-eval.} [dB(A)]	250 Pa								Summation L _{w(eq)A-eval.} [dB(A)]	500 Pa								
				Octave power level*									Octave power level*									Octave power level*								
				L _w [dB/octave]									L _w [dB/octave]									L _w [dB/octave]								
63 Hz	125 Hz	250 Hz	500 Hz	1000 Hz	2000 Hz	4000 Hz	8000 Hz	63 Hz	125 Hz	250 Hz	500 Hz	1000 Hz	2000 Hz	4000 Hz	8000 Hz	63 Hz	125 Hz	250 Hz	500 Hz	1000 Hz	2000 Hz	4000 Hz	8000 Hz							
200	100	2,8	202	48	47	46	44	42	40	37	35	48	56	55	54	52	50	48	45	43	59	62	61	60	58	56	54	51	49	62
		6,3	435	53	53	52	50	49	47	45	42	54	61	61	60	58	57	55	53	50	62	67	67	66	64	63	61	59	56	68
		9,7	698	-	-	-	-	-	-	-	-	-	64	64	63	62	61	59	57	59	66	70	70	69	68	67	65	63	61	72
300	100	2,0	216	46	45	44	42	40	37	35	32	45	54	53	52	50	48	45	43	40	53	60	59	58	56	54	51	49	46	59
		4,7	508	53	52	51	49	47	45	43	40	53	61	60	59	57	55	53	51	48	61	67	66	65	63	61	59	57	54	67
		7,4	799	-	-	-	-	-	-	-	-	-	64	63	62	61	59	57	55	53	65	70	69	68	67	65	63	61	59	71
400	100	2,1	302	47	46	45	43	41	38	35	32	46	55	54	53	51	49	46	43	40	54	61	60	59	57	55	52	49	46	60
		4,9	705	53	53	51	50	48	46	44	41	54	61	60	59	58	56	54	52	49	62	67	66	65	64	62	60	58	55	68
		7,6	1094	-	-	-	-	-	-	-	-	-	64	64	63	61	60	58	56	53	65	70	70	69	67	66	64	62	59	71
150	150	3	243	49	48	47	45	43	41	39	36	49	57	56	55	53	51	49	47	44	57	63	62	61	59	57	55	53	50	63
		6	486	54	54	52	51	49	48	45	43	55	62	61	60	59	57	55	53	51	63	68	67	66	65	63	62	59	57	69
		9	729	57	56	56	54	53	51	49	47	58	65	64	63	62	61	59	57	55	66	71	70	69	68	67	65	63	61	72
300	150	3	486	52	50	49	47	45	43	40	37	50	60	58	57	55	53	51	48	45	58	66	64	63	61	59	57	54	51	64
		6	972	56	56	54	53	51	49	47	44	57	64	64	62	61	59	57	55	52	65	70	70	68	67	65	63	61	58	71
		9	1458	59	59	58	56	55	53	51	48	60	67	66	66	64	63	61	59	56	68	73	73	72	70	69	67	65	62	74
200	200	3	432	52	50	49	47	45	43	40	37	50	60	58	57	55	53	51	48	45	58	66	64	63	61	59	57	54	51	64
		6	864	56	56	54	53	51	49	47	44	57	64	64	62	61	59	57	55	52	65	70	70	68	67	65	63	61	58	71
		9	1296	59	59	58	56	55	53	51	48	60	67	66	66	64	63	61	59	56	68	73	73	72	70	69	67	65	62	74
300	200	3	648	53	52	50	48	46	44	41	38	51	61	60	58	56	54	52	49	46	59	67	66	64	62	60	58	55	52	65
		6	1296	58	57	56	54	52	50	48	45	58	66	65	64	62	60	58	56	53	66	72	71	70	68	66	64	62	59	72
		9	1944	61	60	59	57	56	54	52	49	61	69	68	67	65	64	62	59	57	69	75	74	73	71	70	68	65	63	75
400	200	3	864	54	52	51	49	47	44	41	38	52	62	60	59	57	55	52	49	46	60	68	66	65	63	61	58	55	52	66
		6	1728	59	58	56	55	53	51	48	45	58	67	66	64	63	61	59	56	53	66	73	72	70	69	67	65	62	59	72
		9	2592	61	61	60	58	56	54	52	49	62	69	69	68	66	64	62	60	57	70	75	75	74	72	70	68	66	63	76
300	300	3	972	54	53	51	49	47	45	42	39	53	62	61	59	57	55	53	50	47	61	68	67	65	63	61	59	56	53	67
		6	1944	60	58	57	56	54	51	49	46	59	67	66	65	63	62	59	57	54	67	74	72	71	69	68	65	63	60	73
		9	2916	62	62	60	59	57	55	53	50	63	70	69	68	67	65	63	61	58	71	76	75	74	73	71	69	67	64	77
450	300	3	1458	56	54	53	50	48	46	43	39	54	64	62	60	58	56	53	51	47	62	70	68	67	64	62	59	57	53	68
		6	2916	61	60	58	57	55	52	50	47	60	69	68	66	65	63	60	58	55	68	75	74	72	71	69	66	64	61	74
		9	4374	64	63	62	60	58	56	54	51	64	72	71	70	68	66	64	62	59	72	78	77	76	74	72	70	68	65	78
600	300	3	1944	56	55	53	51	49	46	43	40	54	64	63	61	59	57	54	51	48	62	70	69	67	65	63	60	57	54	68
		6	3888	62	60	59	57	55	53	50	47	61	70	68	67	65	63	61	58	55	69	76	74	73	71	69	67	64	61	75
		9	5832	65	64	62	61	59	57	54	51	64	73	72	70	69	67	65	62	59	72	79	78	76	75	73	71	68	65	78

* Sound level in dB/octave in relation to 10⁻¹² W

If air is blown into a room, additional attenuation occurs as a result of the duct outlet attenuation and room attenuation and because of that, a reduction in the sound level.

The room and outlet attenuation can be calculated according to VDI 2081. As a rough estimate, approx. 8 dB can be deducted. To keep a required noise pressure level, it can be necessary to assemble a suitable sound attenuator between the volume flow controller and the room or to insulate the duct.

The flow noise is heavily dependent on local conditions, e.g. dimensions of the duct (height, width, length) behind the sound attenuator and the insulation of the duct. The specified data above, which have been acquired in the laboratory, can provide only a reference figure. The noise pressure level can rise if there is an additional noise source such as a ventilator or unfavourable air flow conditions. If this additional noise pressure level is smaller than approx. 10 dB of the noise pressure level of the volume flow controller, it will have no increasing effect on the addition of both.



Aerotechnik E. Siegwart GmbH
 Untere Hofwiesen · D-66299 Friedrichsthal
 ☎ +49 (0) 6897/859-0 · 📠 +49 (0) 6897/859-150
 www.aerotechnik.de · info@aerotechnik.de

Constant volume flow controller self regulating - rectangular

Table 2: Correction values for calculation of the radiating noise of a duct (length 6 m) with fitted volume flow

Width [mm]	Height [mm]	Duct according to DIN 24190								Insulation with 1 mm sheet steel and 30 mm mineral wool							
		Correction value [dB/octave]								Correction value [dB/octave]							
		63 Hz	125 Hz	250 Hz	500 Hz	1000 Hz	2000 Hz	4000 Hz	8000 Hz	63 Hz	125 Hz	250 Hz	500 Hz	1000 Hz	2000 Hz	4000 Hz	8000 Hz
200	100	0	2	3	4	6	7	8	7	0	4	7	12	16	18	18	16
300	100	0	5	6	8	9	11	10	9	0	7	10	16	19	22	20	18
400	100	0	5	6	8	9	11	10	9	0	7	10	16	19	22	20	18
150	150	0	2	2	3	4	6	7	8	0	4	6	11	14	17	17	17
300	150	0	4	5	6	8	9	11	11	0	6	9	14	18	20	21	20
200	200	0	2	2	3	4	6	7	8	0	4	6	11	14	17	17	17
300	200	0	4	5	6	8	9	11	11	0	6	9	14	18	20	21	20
400	200	0	4	5	6	8	9	11	11	0	6	9	14	18	20	21	20
300	300	0	3	4	5	6	8	9	11	0	5	8	13	16	19	19	20
450	300	0	4	4	6	7	9	10	12	0	6	8	14	17	20	20	21
600	300	0	4	4	6	7	9	10	12	0	6	8	14	17	20	20	21

Example: Calculation of the noise pressure level

Frequency →	Noise pressure level [dB/octave]								Summation $L_{w,calc}$ A-eval. [dB(A)]
	63 Hz	125 Hz	250 Hz	500 Hz	1000 Hz	2000 Hz	4000 Hz	8000 Hz	
Flow noise L_w according to table 1	53	52	50	48	46	44	41	38	51
Correction Value according to table 2	0	-6	-9	-14	-18	-20	-21	-20	-
Room attenuation	-4	-4	-4	-4	-4	-4	-4	-4	-
A-evaluation	-26	-16	-9	-3	0	1	1	-1	-
Noise pressure level L_A A-evaluated dB (A)	23	26	28	27	24	21	17	13	33

Example:

Given: Volume flow controller Type VRRK, ref. no. 500 with 30 mm insulating shell Width 300 mm, height 200 mm Volume flow 648 m³/h (= velocity 3 m/s) Static pressure difference Δp 100 Pa

Noise pressure level of a duct (length 6 m) with integrated volume flow controller?

Calculated noise pressure level: 33 dB (A)

Example: Calculation of the flow noise

Frequency →	Noise pressure level [dB/octave]								Summation $L_{w,calc}$ A-eval. in dB(A)
	63 Hz	125 Hz	250 Hz	500 Hz	1000 Hz	2000 Hz	4000 Hz	8000 Hz	
Flow noise L_w according to table 1	53	52	50	48	46	44	41	38	51
Reflection attenuation	-18	-10	-5	-1	0	0	0	0	-
Room attenuation	-4	-4	-4	-4	-4	-4	-4	-4	-
A-evaluation	-26	-16	-9	-3	0	1	1	-1	-
Noise pressure level L_A A-evaluated [dB (A)]	5	22	32	40	42	41	38	33	46

Example:

Given: Volume flow controller Type VRRK, ref. no. 500 with 30 mm insulating shell Width 300 mm, height 200 mm Volume flow 648 m³/h (= velocity 3 m/s) Static pressure difference Δp 100 Pa

Noise pressure level of a duct (length 6 m) with integrated volume flow controller?

Calculated noise pressure level: 46 dB (A)



Aerotechnik E. Siegwart GmbH
 Untere Hofwiesen · D-66299 Friedrichsthal
 ☎ +49 (0) 6897/859-0 · 📠 +49 (0) 6897/859-150
 www.aerotechnik.de · info@aerotechnik.de

Ref. no.: 500 - 506

Constant volume flow controller self regulating - rectangular

Twin controller

Starting with height of 400 mm our execution
will be a twin controller with two control plates.

All twin controllers are equipped with two control plates each with their own adjustment device with flow rate scale. The summation of both of the scale values results in the total volume flow rate.

- rectangular, self regulating
- flow rate factory-preset, manual setting of the flow rate by the customer via a scale
- made of galvanized steel or of stainless steel

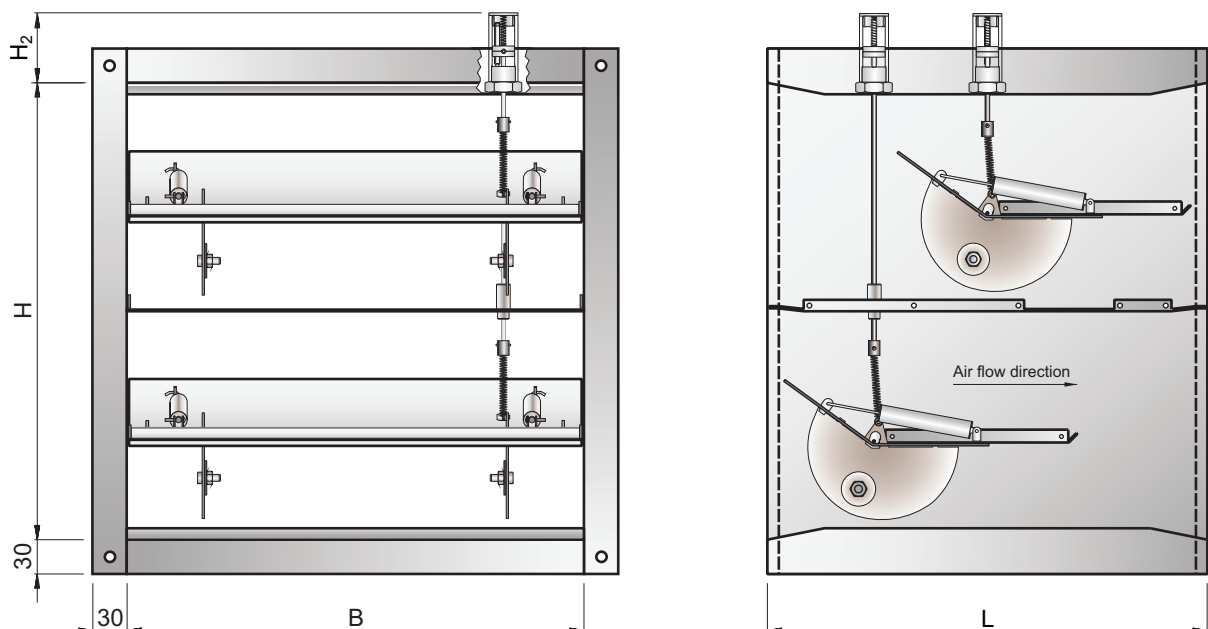

Aerotechnik E. Siegwart GmbH
Untere Hofwiesen · D-66299 Friedrichsthal
☎ + 49 (0) 6897/859-0 · 📠 +49 (0) 6897/859-150
www.aerotechnik.de · info@aerotechnik.de

Constant volume flow controller self regulating - rectangular

Table 1: Flow noise

Width [mm]	Height [mm]	Velocity [m/s]	Volume flow [m³/h]	Static pressure difference at the controller [Pa]																											
				100 Pa								Summation L _{w,stat} A-eval. in dB(A)	250 Pa								Summation L _{w,stat} A-eval. in dB(A)	500 Pa									
				Octave power level*									Octave power level*									Octave power level*									
				L _w [dB/octave]									L _w [dB/octave]									L _w [dB/octave]									
63 Hz	125 Hz	250 Hz	500 Hz	1000 Hz	2000 Hz	4000 Hz	8000 Hz	63 Hz	125 Hz	250 Hz	500 Hz	1000 Hz	2000 Hz	4000 Hz	8000 Hz	63 Hz	125 Hz	250 Hz	500 Hz	1000 Hz	2000 Hz	4000 Hz	8000 Hz								
400	400	3	1728	56	55	53	51	49	46	43	40	54	64	63	61	59	57	54	51	48	62	70	69	67	65	63	60	57	54	68	
		6	3456	62	60	59	57	55	53	50	47	61	70	68	67	65	63	61	58	55	69	76	74	73	71	69	67	64	61	75	
		9	5184	-	-	-	-	-	-	-	-	-	73	72	70	69	67	65	62	59	72	79	78	76	75	73	71	68	65	78	
500	400	3	2160	57	56	54	52	49	46	43	40	55	65	64	62	60	57	54	51	48	63	71	70	68	66	63	60	57	54	69	
		6	4320	62	61	60	58	56	53	51	48	61	70	69	68	66	64	61	59	56	69	76	75	74	72	70	67	65	62	75	
		9	6480	-	-	-	-	-	-	-	-	-	73	72	71	69	67	65	63	60	73	79	78	77	75	73	71	69	66	79	
600	400	3	2592	58	56	54	52	50	47	44	41	55	66	64	62	60	58	55	52	48	63	72	70	68	66	64	61	58	54	69	
		6	5184	63	62	60	58	56	54	51	48	62	71	70	68	66	64	62	59	56	69	77	76	74	72	70	68	65	62	76	
		9	7776	-	-	-	-	-	-	-	-	-	74	73	71	70	68	65	63	60	73	80	79	77	76	74	71	69	66	79	
500	500	3	2700	58	56	54	52	50	47	44	41	55	66	64	62	60	58	55	52	49	63	72	70	68	66	64	61	58	55	69	
		6	5400	63	62	60	59	56	54	51	48	62	71	70	68	66	64	62	59	56	70	77	76	74	73	70	68	65	62	76	
		9	8100	-	-	-	-	-	-	-	-	-	74	73	72	70	68	66	63	60	73	80	79	78	76	74	72	69	66	79	
600	500	3	3240	58	56	55	53	50	47	44	41	56	66	65	63	61	58	55	52	49	64	72	71	69	67	64	61	58	55	70	
		6	6480	64	62	61	59	57	54	51	48	62	72	70	69	67	64	62	59	56	70	78	77	75	73	71	68	65	62	76	
		9	9720	-	-	-	-	-	-	-	-	-	75	74	72	71	68	66	63	61	74	81	80	78	77	74	72	70	67	80	
600	600	3	3888	59	57	55	53	51	48	45	41	56	67	65	63	61	59	56	53	49	64	73	71	69	67	65	62	59	55	70	
		6	7776	65	63	62	60	57	55	52	49	63	72	71	69	68	65	62	60	57	71	78	77	76	74	71	69	66	63	77	
		9	11664	-	-	-	-	-	-	-	-	-	75	74	73	71	69	67	64	61	74	82	80	79	77	75	73	70	67	80	

* Sound level in dB/octave in relation to 10⁻¹² W

Table 2: Correction values for calculation of the radiating noise of a duct (length 6 m) with fitted volume flow

Width [mm]	Height [mm]	Duct without insulation								Duct with 30 mm insulating shell							
		Correction value [dB/octave]								Correction value [dB/octave]							
		63 Hz	125 Hz	250 Hz	500 Hz	1000 Hz	2000 Hz	4000 Hz	8000 Hz	63 Hz	125 Hz	250 Hz	500 Hz	1000 Hz	2000 Hz	4000 Hz	8000 Hz
400	400	0	3	4	5	6	8	9	11	0	5	8	13	16	19	19	20
500	400	0	4	4	6	7	9	10	10	0	6	8	14	17	20	20	19
600	400	0	4	4	6	7	9	10	10	0	6	8	14	17	20	20	19
500	500	0	4	4	6	7	9	10	10	0	6	8	14	17	20	20	19
600	500	0	4	4	6	7	9	10	10	0	6	8	14	17	20	20	19
600	600	0	4	4	6	7	9	10	10	0	6	8	14	17	20	20	19

Because of aerodynamic conditions and because of stability reasons, the width should be maximum twice the height; the width must not be smaller than the height [H ≤ B ≤ 2H].

Specifications

Manufacturer: AEROTECHNIK E. Siegwart
Type: VRRK, Ref. no. 500

Constant volume flow controller, mechanical, self regulating, rectangular, flange C30, flow rate factory-preset, manual setting of the flow rate by the customer via a scale, high accuracy of the volume flow, smooth-running and airtightly installed control plate, range of static pressure difference 50 Pa to 1000 Pa, range of volume flow 3:1, range of temperature -20° C to +100° C, ageing-resistant, maintenance-free, precise control in any installation situation.

Housing made of galvanized steel, control plate and vibration damper made of aluminium, bearings made of PTFE. Housing leakage according to DIN EN 1751 class C.



Aerotechnik E. Siegwart GmbH
 Untere Hofwiesen · D-66299 Friedrichsthal
 ☎ +49 (0) 6897/859-0 · 📠 +49 (0) 6897/859-150
 www.aerotechnik.de · info@aerotechnik.de